

PSEnvip RL D P Set



Safe camera systems

This document is a translation of the original document.

All rights to this documentation are reserved by Pilz GmbH & Co. KG. Copies may be made for internal purposes.

Suggestions and comments for improving this documentation will be gratefully received.

Pilz[®], PIT[®], PMI[®], PNOZ[®], Primo[®], PSEN[®], PSS[®], PVIS[®], SafetyBUS p[®], SafetyEYE[®], SafetyNET p[®], the spirit of safety[®] are registered and protected trademarks of Pilz GmbH & Co. KG in some countries.



SD means Secure Digital.

Contents		Page
Chapter 1	Introduction	
1.1	Validity of the documentation	1-2
1.2	Overview of documentation	1-3
1.3	Definition of symbols	1-5
Chapter 2	Overview	
2.1	Scope of supply	2-3
Chapter 3	Safety	
3.1	Intended use	3-1
3.1.1	Approvals	3-2
3.1.2	Safety during operation	3-2
3.1.2.1	Hazards arising from the installation of the PSEnvip	3-2
3.1.2.2	Hazards arising from a reduced protected field	3-2
3.1.2.3	Hazards arising from incorrect handling of the workpiece	3-3
3.1.2.4	Correct handling of the workpiece	3-3
3.1.3	Categories / SIL	3-6
3.1.4	Tool shapes	3-6
3.2	Standards	3-9
3.3	Safety guidelines	3-10
3.3.1	Use of qualified personnel	3-10
3.3.2	EMCD	3-10
3.3.3	Warranty and liability	3-11
3.3.4	Safety during commissioning, installation and operation	3-11
3.3.5	Disposal	3-11
Chapter 4	Function description	
4.1	Overview	4-1
4.2	Protected field	4-5
4.2.1	Dynamic muting	4-6
4.2.2	Standard interrupted press stroke	4-8
4.3	Overrun	4-10
4.4	Description of the units	4-11
4.4.1	Overview	4-11
4.4.2	Transmitter	4-11
4.4.2.1	Inputs	4-11
4.4.3	Receiver	4-12
4.4.3.1	Inputs	4-12
4.4.3.2	Outputs	4-14

4.4.3.3	LED	4-16
4.4.3.4	Key display and function	4-17
4.4.4	Communication with the safety system	4-20
4.5	Protected field modes	4-24
4.5.1	Standard protected field mode	4-24
4.5.2	Box bending protected field mode	4-25
4.5.3	Back gauge protected field mode	4-26
4.5.4	Box bending with back gauge protected field mode	4-27
4.6	Operating modes during commissioning	4-28
4.6.1	Press brake setup mode	4-28
4.6.2	Adjustment during initial commissioning	4-28
4.6.3	Adjustment during tool change	4-28
4.7	System cycle	4-30
4.7.1	System cycle for standard press stroke	4-31
4.7.2	System cycle for box bending press stroke	4-34
4.7.3	System cycle for back gauge press stroke	4-37
4.7.4	System cycle for box bending with back gauge press stroke	4-37
Chapter 5 Installation		
5.1	General requirements	5-1
5.2	Install transmitter and receiver	5-2
5.3	Dimensions	5-4
5.3.1	Transmitter	5-4
5.3.2	Receiver	5-5
5.3.3	Fastening kit for the transmitter	5-5
5.3.4	Fastening kit for the receiver	5-6
5.3.5	Bracket for transmitter and receiver	5-7
Chapter 6 Wiring		
6.1	Notes on wiring	6-1
6.2	Connections	6-4
6.2.1	Receiver	6-4
6.2.2	Transmitter	6-6
6.2.3	Supply voltage	6-6
6.2.4	Connection between transmitter and receiver	6-6
6.2.5	Connection diagram	6-7
Chapter 7 Commissioning		
7.1	Commissioning guidelines	7-1
7.2	Initial commissioning	7-2
7.2.1	Align transmitter and receiver	7-2
7.2.1.1	Prepare for alignment	7-2

7.2.1.2	Adjustment templates	7-2
7.2.1.3	Adjustment directions of transmitter and receiver	7-3
7.2.1.4	Align transmitter	7-5
7.2.1.5	Tool shapes	7-6
7.2.1.6	Align receiver	7-8
7.2.2	Adjustment template with bracket	7-11
7.3	Adjustment during tool change	7-13
7.3.1	Prepare for adjustment during tool change	7-13
7.3.2	Tool detection	7-13
7.3.3	Make adjustment during tool change	7-16
7.4	Enter overrun	7-19
7.5	Check protective equipment	7-21
7.5.1	Function test of the safety device	7-21
7.5.1.1	Test during initial commissioning	7-22
7.5.1.2	Test after machine modification	7-22
7.5.1.3	Regular check	7-22
7.5.1.4	Prepare for function test	7-23
7.5.1.5	Function test using the test piece	7-23
7.5.2	Visual inspection	7-25
Chapter 8 Operation		
8.1	Safety guidelines	8-1
8.2	Operating notes	8-2
8.2.1	Switch on PSEnvip	8-2
8.2.2	Muting lamp	8-2
8.2.3	Initial press stroke	8-2
8.2.4	Acknowledge protected field modes	8-3
8.2.5	Tool change	8-4
8.2.6	Error messages	8-4
8.2.7	Cleaning the front lenses	8-5
Chapter 9 Diagnostics and Troubleshooting		
9.1	Error Management	9-2
9.1.1	Minor errors	9-2
9.1.2	Major errors	9-2
9.1.3	Fatal errors	9-3
9.2	Error messages	9-4
9.3	DIAGNOSTICS menu	9-6
9.3.1	Diagnostic blocks and diagnostic data	9-6
Chapter 10 System Connections		
10.1	Requirements of the user program	10-1
10.2	Communication with the safety system	10-2

Chapter 11	Technical details	
11.1	Technical details	11-1
11.2	Order reference	11-3
Chapter 12	Attachment	
12.1	Check list	12-1
12.2	EC declaration of conformity	12-4

This operating manual contains information about the intended operation of the PSEnvip. The PSEnvip is a camera-based protection system for press brakes.

This operating manual is aimed at manufacturers, company operators and personnel involved in designing, maintaining and operating press brakes, which are to be safeguarded using the PSEnvip.

This operating manual is not an instruction manual for the press brake that is safeguarded using the PSEnvip. Please refer to the press brake operating manual for this information.

This documentation is intended for instruction and should be retained for future reference.

1 Introduction

1.1 Validity of the documentation

This documentation is valid for the product **PSEnvip RL D P Set**. It is valid until new documentation is published.

This documentation is valid for the PSEnvip from Version 2.2/year of construction 2013.

1.2 Overview of documentation

1 Introduction

The introduction is designed to familiarise you with the contents, structure and specific order of this manual.

2 Overview

This chapter provides information on the PSEnvip's most important features.

3 Safety

This chapter must be read as it contains important information on safety and intended use.

4 Function Description

This chapter provides an overview of the PSEnvip's mode of operation. It describes the units and the system procedures.

5 Installation

This chapter explains how to install the PSEnvip.

6 Wiring

This chapter explains how to wire the inputs and outputs on the PSEnvip.

7 Commissioning

This chapter explains how to commission the PSEnvip. It contains information on adjustments and on the tests performed on the safety device.

8 Operation

This chapter contains all the information required by the operator.

9 Diagnostics and Troubleshooting

This chapter describes the output of diagnostics on the display and explains how to handle errors.

1 Introduction

1.2 Overview of documentation

10 System Connections

This chapter describes how the PSEnvip is connected to the press brake's programmable safety system.

11 Technical Details

12 Appendix

1.3 Definition of symbols

Information that is particularly important is identified as follows:



DANGER!

This warning must be heeded! It warns of a hazardous situation that poses an immediate threat of serious injury and death and indicates preventive measures that can be taken.



WARNING!

This warning must be heeded! It warns of a hazardous situation that could lead to serious injury and death and indicates preventive measures that can be taken.



CAUTION!

This refers to a hazard that can lead to a less serious or minor injury plus material damage, and also provides information on preventive measures that can be taken.



NOTICE

This describes a situation in which the unit(s) could be damaged and also provides information on preventive measures that can be taken. It also highlights areas within the text that are of particular importance.



INFORMATION

This gives advice on applications and provides information on special features.

The PSEnvip is a camera-based protection and measuring system (electrosensitive protective equipment) for press brakes. It consists of a transmitter and receiver. The PSEnvip monitors the detection zone between the transmitter and receiver below the moving upper tool.

Transmitter

- ▶ Generates parallel beam
- ▶ 2 inputs for controlling the light source

Receiver

- ▶ Evaluates the light generated by the transmitter
- ▶ Display for the operating statuses and inputs
- ▶ Membrane keypad for operating the menus and for inputs
- ▶ Max. distance between transmitter and receiver: 10 m

Inputs

- ▶ 1 input for setup mode
- ▶ 1 input for signalling when the press brake is at top dead centre
- ▶ 2 inputs for controlling the protected field mode:
 - Protected field can be adapted to a range of bending functions: full protected field, reduced protected field for box bending and lower tools with back gauge
- ▶ 1 input for acknowledging the protected field mode

Outputs

- ▶ 2 output signal switching devices (OSSD) for signalling the status of the protected field (clear or interrupted)
- ▶ 2 outputs for signalling that PSEnvip is in dynamic muting

Some inputs and outputs are used for communication with the safety system during the system status TEST:

- ▶ Register tool class on safety system
- ▶ Approve tool class for PSEnvip

LED indicators for

- ▶ Status of OSSDs

Operating statuses

- ▶ Adjustment for initial commissioning
- ▶ Tool change
- ▶ Diagnostics

Tool detection

- ▶ Automatic detection of tool contour during tool change
- ▶ Assignment of tool to a tool class

The whole system consists of:

- ▶ Press brake
- ▶ Numerical controller (CNC)
- ▶ Programmable safety system
- ▶ PSEnvip (transmitter and receiver)

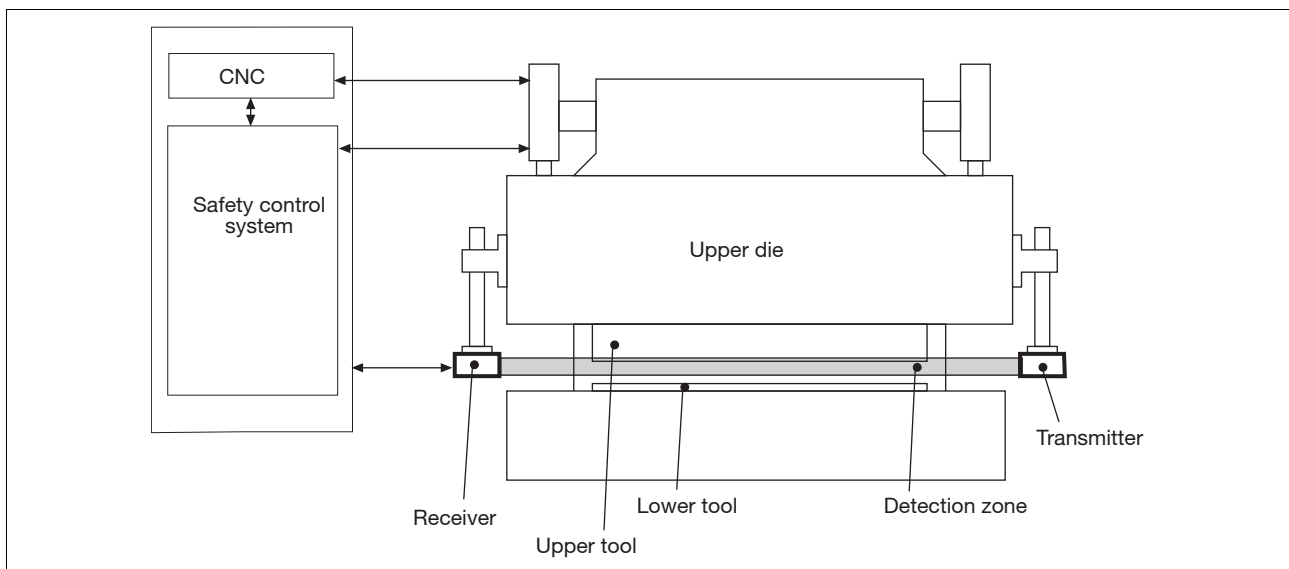
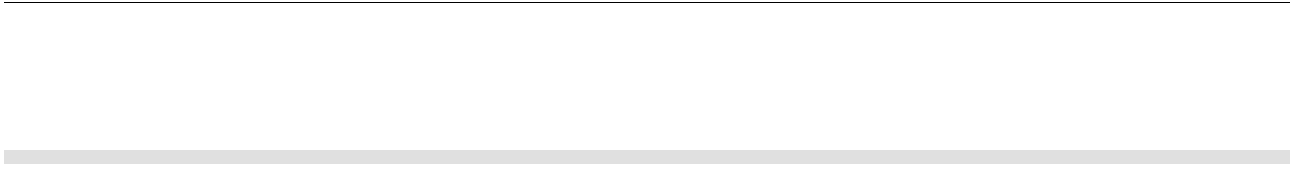

Fig. 2-1: Whole system

2.1 Scope of supply

PSEnvip RL D P Set: complete set

Order reference	Description
PSEnvip RL D P	PSEnvip receiver, left, with display and dynamic muting
PSEnvip T	PSEnvip transmitter
PSEnvip AT mag	Adjustment templates with magnets
PSEnvip AP	Set of adjustment plates for transmitter/receiver
PSEnvip TP	Test piece in accordance with EN 12622, Annex H
DVD with operating manuals	



3.1 Intended use

The PSEnvip is exclusively designed for stationary use on press brakes. As electrosensitive protective equipment (ESPE), the PSEnvip meets the requirements of a type 4 ESPE in accordance with EN 61496-1.

The PSEnvip safeguards the danger zone below the moving upper tool.

Danger zones outside of the protected field are not protected. Hazards in the area of the lower tool and above the protected field must be protected by the press manufacturer with appropriate measures. Please refer to the guidelines given in the "Tool shapes" section in this chapter.

The protected field monitors the danger zone between upper tool and plate up to a remaining gap of 6 mm (dynamic muting)

The upward movement of the press is assumed as a safe movement.

Use of the **PSEnvip RL D P Set** is only permitted with the automation system PSS 4000 from Pilz. In the PSS 4000 user program, safety functions must be implemented to safeguard the dynamic muting of PSEnvip:

- ▶ Monitoring of the pinch point
- ▶ Monitoring of the press braking ramp
- ▶ Definition of a safe position and safe speed for the upper tool
- ▶ Activation of the entire protected field via System-Init = 1, when the press stops during dynamic muting and then the upward movement is initiated.

For this safety function Pilz provides a certified evaluation program for the PSS 4000.

The press brake must observe a max. overrun of 14 mm.

The following is deemed improper use:

- ▶ Any structural, technical or electrical modification to the PSEnvip
- ▶ Use of the PSEnvip outside the zones described in this manual
- ▶ Use of the PSEnvip contrary to the documented technical details (see chapter entitled "Technical Details")

Intended use includes making the wiring EMC-compliant. Please refer to the guidelines stated in this manual, in the section entitled "Wiring".

The protective function of the PSEnvip must not be adversely affected by sources of interference, e.g. wireless remote controls for cranes, welding sparks, strobe lighting effects.

3.1 Intended use

3.1.1 Approvals

	✓
	✓
	✓

3.1.2 Safety during operation

Intended use also includes awareness of the hazards that arise during operation, against which the PSEnvip does not provide protection.

3.1.2.1 Hazards arising from the installation of the PSEnvip

When installing the PSEnvip, please note the following:

- ▶ The PSEnvip must be installed so that there are no crushing or shearing hazards between the moving transmitter/receiver and the fixed machine parts or any other parts around the machine.
- ▶ If hazard areas cannot be avoided, other safeguards must be put in place.

3.1.2.2 Hazards arising from a reduced protected field

The full protected field is only active in standard protected field mode. In box bending or box bending with back gauge protected field mode, the protected field is reduced. This means there can only be limited protection against trapping and crushing. The protected field is around the tolerance zone behind the bending line. Any parts of the body within the danger zone will only be detected behind the bending line. There is a risk of injury from trapping or crushing.

3.1 Intended use

3.1.2.3 Hazards arising from incorrect handling of the workpiece

The PSEnvip does not protect against hazards arising from incorrect handling of the workpiece.

When bending metal sheets on press brakes there is a risk of hand injuries

- ▶ From the tool's closing movement
- ▶ From the swivel movement of the parts of the metal sheet that protrude from the tool and
- ▶ From the dropping of the metal sheet when the tool is opened.

So please note the following:

- ▶ You can avoid crushing and trapping of fingers or hands if the workpiece is handled correctly.
- ▶ Wear protective gloves to prevent cuts from edges, corners and ridges.

3.1.2.4 Correct handling of the workpiece



WARNING!

Crushing and trapping of fingers or hands!

With box bending and/or back gauge bending mode, the protected field is partly blanked.

Around the bending line there is an increased risk of crushing and trapping of fingers or hands.

3.1 Intended use

Correct handling with flat workpieces

- ▶ Grip the metal sheet by the front corners. Thumbs should be on top of the sheet, palms should hold the sheet from below.

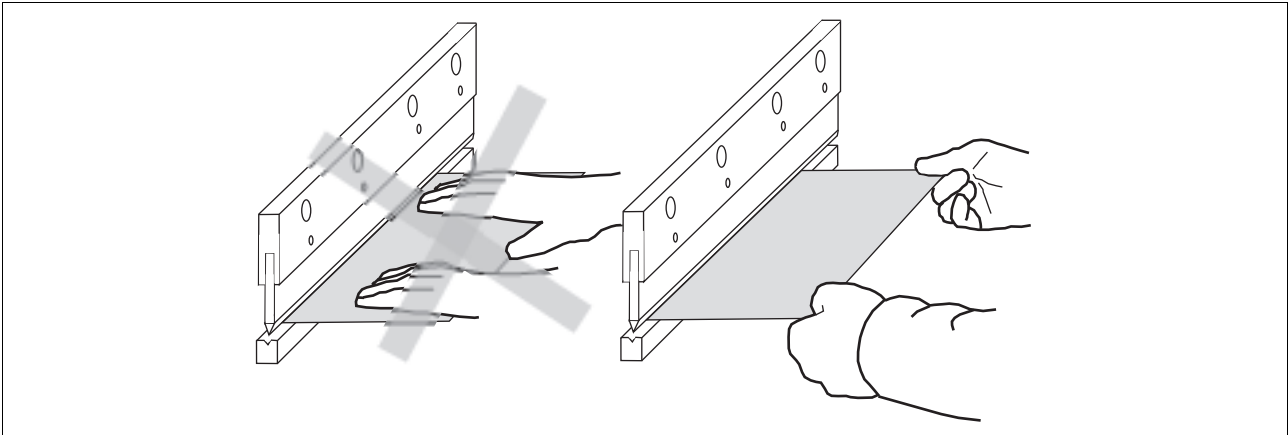

Fig. 3-1: Handling flat workpieces

3.1 Intended use

Correct handling with box bending

- ▶ Hold the sheet on the right and left between the thumb and index finger.
- ▶ As you hold the sheet, do not reach with your hands into the box. During the bending operation, fingers or hands can become crushed or trapped between the workpiece and upper tool.

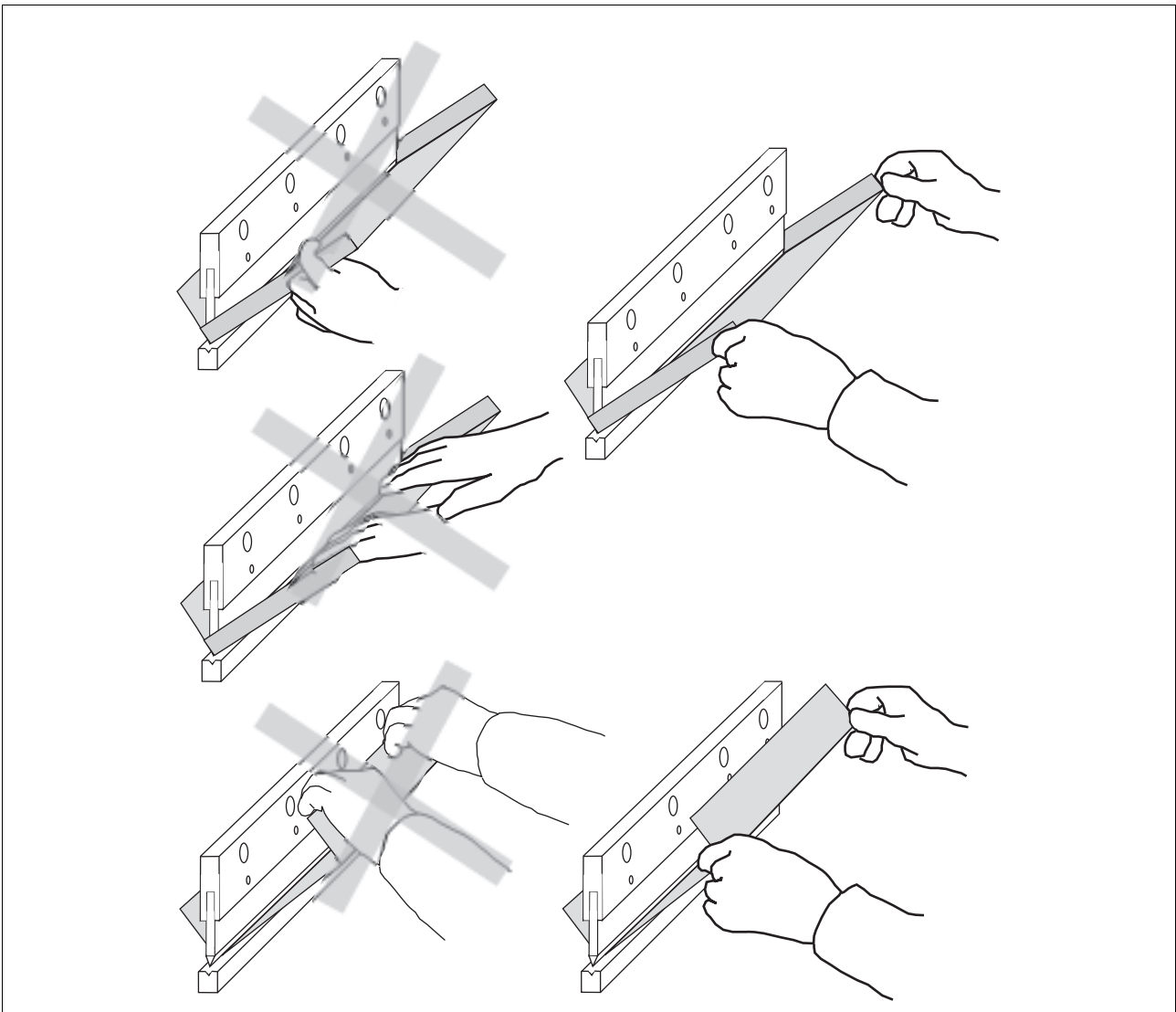

Fig. 3-2: Handling box bending

3.1 Intended use

3.1.3 Categories / SIL

The PSEnvip may only be used with an automation system PSS 4000 from Pilz with SIL 3 of EN 61508 and PL e of EN ISO 13849-1.

Please note: To achieve the corresponding category or SIL, the whole system including all safety-related components (parts, devices, user program etc.) must be included in the assessment. For this reason, Pilz cannot accept liability for the correct classification into a category or SIL.

3.1.4 Tool shapes

All tool shapes are permitted in principle. They are divided into tool classes by the PSEnvip. Classification is based on EN 12622, according to which the protected field must safeguard areas lying 15 mm in front of the bending line.



INFORMATION

Please refer to the information on tool classes

- ▶ In the section entitled "Adjustment during tool change", under "Commissioning".
- ▶ In the section entitled "Requirements of the user program", under "System Connections".

Please note the following when using tools:

Tool class 1

- ▶ These tools can be safeguarded in compliance with the standards: The front and rear bending lines are detected by the protected field on the PSEnvip. The front segments of the protected field are more than 15 mm away from the front bending line.
- ▶ Upper tools with a width of max. 32 mm or radius of max. 25 mm.
- ▶ Press brakes can travel up to the regular switchover point at high closing speed.

Tool class 2

- ▶ These tools cannot be safeguarded in compliance with the standards: The front and rear bending lines are detected by the protected field on the PSEnvip. The front segments of the protected field are less than 15 mm away from the front bending line.
- ▶ Upper tools with a width of max. 43 mm or radius of max. 50 mm.

3.1 Intended use

- ▶ The following safety guideline applies for press brakes with tools in this tool class.



WARNING!

Crushing and trapping of fingers or hands!

There may be additional hazard areas in zones that are not monitored by the PSEnvip.

In these zones there is an increased risk of crushing and trapping of fingers or hands.

Secure these zones with appropriate additional measures!

- Carry out a hazard analysis!
- Raise the regular switchover point, which initiates braking at low speed! The switchover point must be monitored by the safety system.

Tool class 3

- ▶ These tools cannot be safeguarded in compliance with the standards: The front and rear bending lines are not detected by the protected field on the PSEnvip.
- ▶ The following safety guideline applies for press brakes with tools in this tool class.



WARNING!

Crushing and trapping of fingers or hands!

There may be additional hazard areas in zones that are not monitored by the PSEnvip.

In these zones there is an increased risk of crushing and trapping of fingers or hands.

Secure these zones with appropriate additional measures!

- Carry out a hazard analysis!
- Raise the switchover point, which initiates braking at low speed. It must be placed even higher than the position used for tools of tool class 2. The switchover point must be monitored by the safety system.
- Each press stroke must be acknowledged by the operator prior to initiation.

3.1 Intended use

Please also note the following guidelines in danger zones in areas that cannot be detected and monitored by the safeguard.

Example: Upper tool with a danger zone outside the zone monitored by the PSEnvip

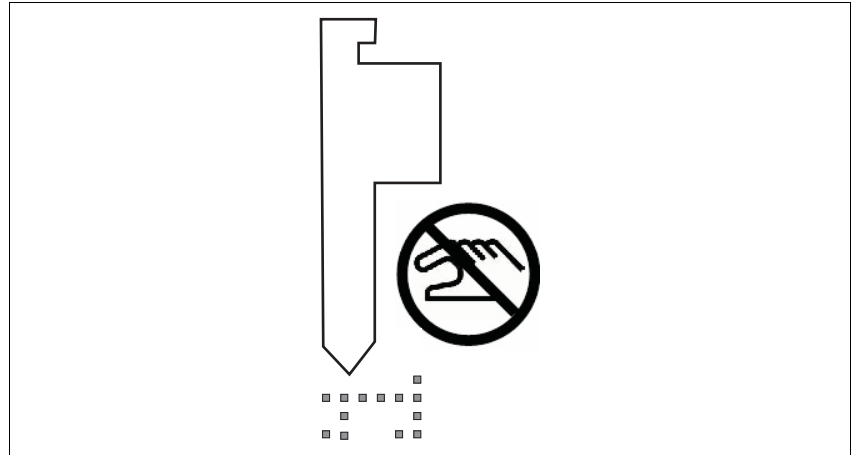

Fig. 3-3: Danger zone in unmonitored zone

Example: In unmonitored zones, the use of tools which are not fully detected by the protected field on the PSEnvip (e.g. tools with a radius greater than 25 mm) will lead to the risk of fingers or hands being crushed or trapped!

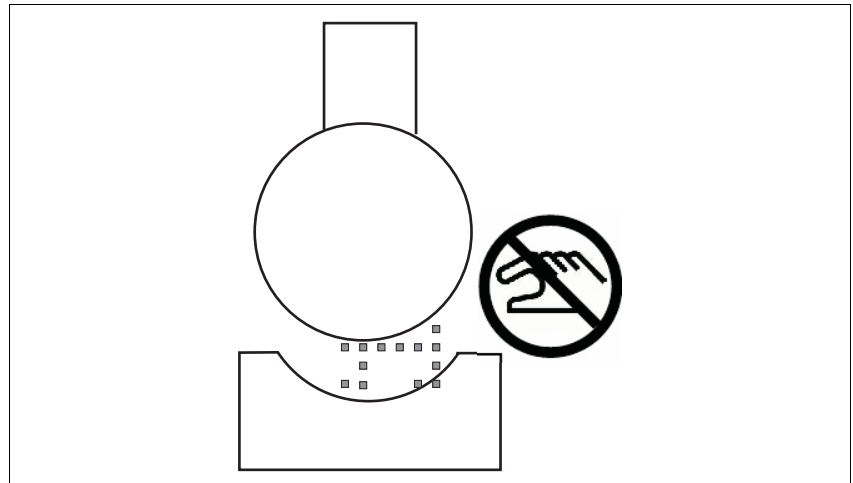

Fig. 3-4: Crush points when the tool is wider than the protected field

3.2 Standards

To use the PSEnvip correctly you will need to have a good knowledge of the relevant standards and directives. The following gives an overview of the most important standards:

- ▶ EN 61496-1:2004: Safety of machinery - Electrosensitive protective equipment, Part 1
- ▶ CLC/TS 61496-2:2006: Safety of machinery - Electrosensitive protective equipment, Part 2
- ▶ EN 12622:2009: Machine tools - Hydraulic press brakes
- ▶ EN ISO 13849-1:2008: Safety of machinery – Safety-related parts of control systems - Part 1: General principles for design
- ▶ EN ISO 13849-2:2008: Safety of machinery – Safety-related parts of control systems - Part 2: Validation
- ▶ EN 61508:2001: Functional safety of safety-related electrical/electronic/programmable electronic systems

Please note this is not an exhaustive list of safety standards and directives.

3.3 Safety guidelines

Failure to keep to these guidelines will render all warranty and liability claims invalid:

- ▶ All health and safety / accident prevention regulations for the particular area of application must be observed.
- ▶ Before using the unit it is necessary to perform a safety assessment in accordance with the Machinery Directive 2006/42/EC.
- ▶ Please note that manufacturers and company operators who use the PSEnvip are themselves responsible for agreeing the regulations with the relevant authorities and complying with them.

3.3.1 Use of qualified personnel

The products may only be assembled, installed, programmed, commissioned, operated, maintained and decommissioned by competent persons.

A competent person is someone who, because of their training, experience and current professional activity, has the specialist knowledge required to test, assess and operate the work equipment, devices, systems, plant and machinery in accordance with the general standards and guidelines for safety technology.

It is the company's responsibility only to employ personnel who:

- ▶ Are familiar with the basic regulations concerning health and safety / accident prevention
- ▶ Have read and understood the safety guidelines given in this description
- ▶ Have a good knowledge of the generic and specialist standards applicable to the specific application.

Approved personnel must be familiar with how to use and test ESPE and be authorised by the ESPE operator to do this.

3.3.2 EMCD

The PSEnvip is designed for use in an industrial environment. It is not suitable for use in a domestic environment, as this can lead to interference.

3.3 Safety guidelines

3.3.3 Warranty and liability

All claims to warranty and liability will be rendered invalid if:

- ▶ The product was used contrary to the purpose for which it is intended
- ▶ Damage can be attributed to not having followed the guidelines in the manual
- ▶ Operating personnel are not suitably qualified
- ▶ Any type of modification has been made (e.g. exchanging components on the PCB boards, soldering work etc.).

3.3.4 Safety during commissioning, installation and operation

Please read the guidelines stated in the chapters entitled "Commissioning", "Installation" and "Operation".

3.3.5 Disposal

- ▶ In safety-related applications, please comply with the mission time t_M in the safety-related characteristic data.
- ▶ When decommissioning, please comply with local regulations regarding the disposal of electronic devices (e.g. Electrical and Electronic Equipment Act).

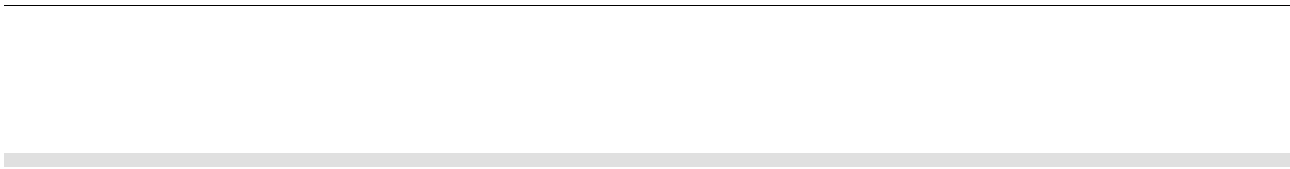

4.1 Overview

The PSEnvip is a camera-based protection system for press brakes. It consists of a transmitter and receiver, which are fixed to the moving part of the press brake, the upper die. The detection zone between the transmitter and receiver monitors the immediate danger zone below the moving upper tool.

The detection zone moves with the upper die, providing mobile safeguarding of the danger zone. If an object encroaches into the detection zone, both output signal switching devices (OSSD1, OSSD2) on the PSEnvip will switch to the OFF-state. The safety system will use these signals to initiate stopping of the press stroke.

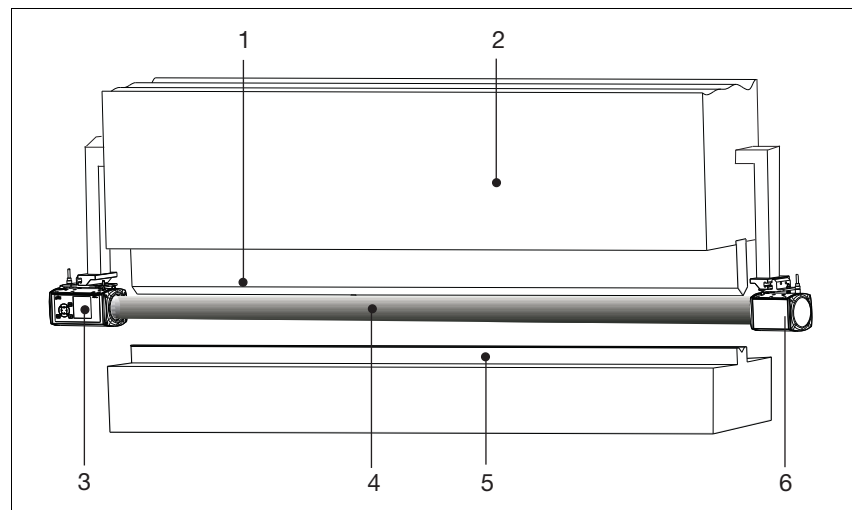

Fig. 4-1: Press brake with PSEnvip

- ▶ 1: Upper tool
- ▶ 2: Upper die
- ▶ 3: Receiver
- ▶ 4: Detection zone
- ▶ 5: Lower tool
- ▶ 6: Transmitter

The PSEnvip is part of an overall system comprising

- ▶ PSEnvip transmitter and receiver
- ▶ Programmable safety system PSS 4000
- ▶ CNC controller
- ▶ Signals from incremental encoders for defining the position and speed
- ▶ External operator elements or signals (foot switch, reset button for reduced protected field or setup mode, E-STOP pushbutton)

4.1 Overview

- ▶ Other safety devices (safety valves, prefill valve, contactor for E-STOP)

The following overview shows the fundamentals of the whole system. The signals from the PSEnvip transmitter and receiver are explained in the sections below.

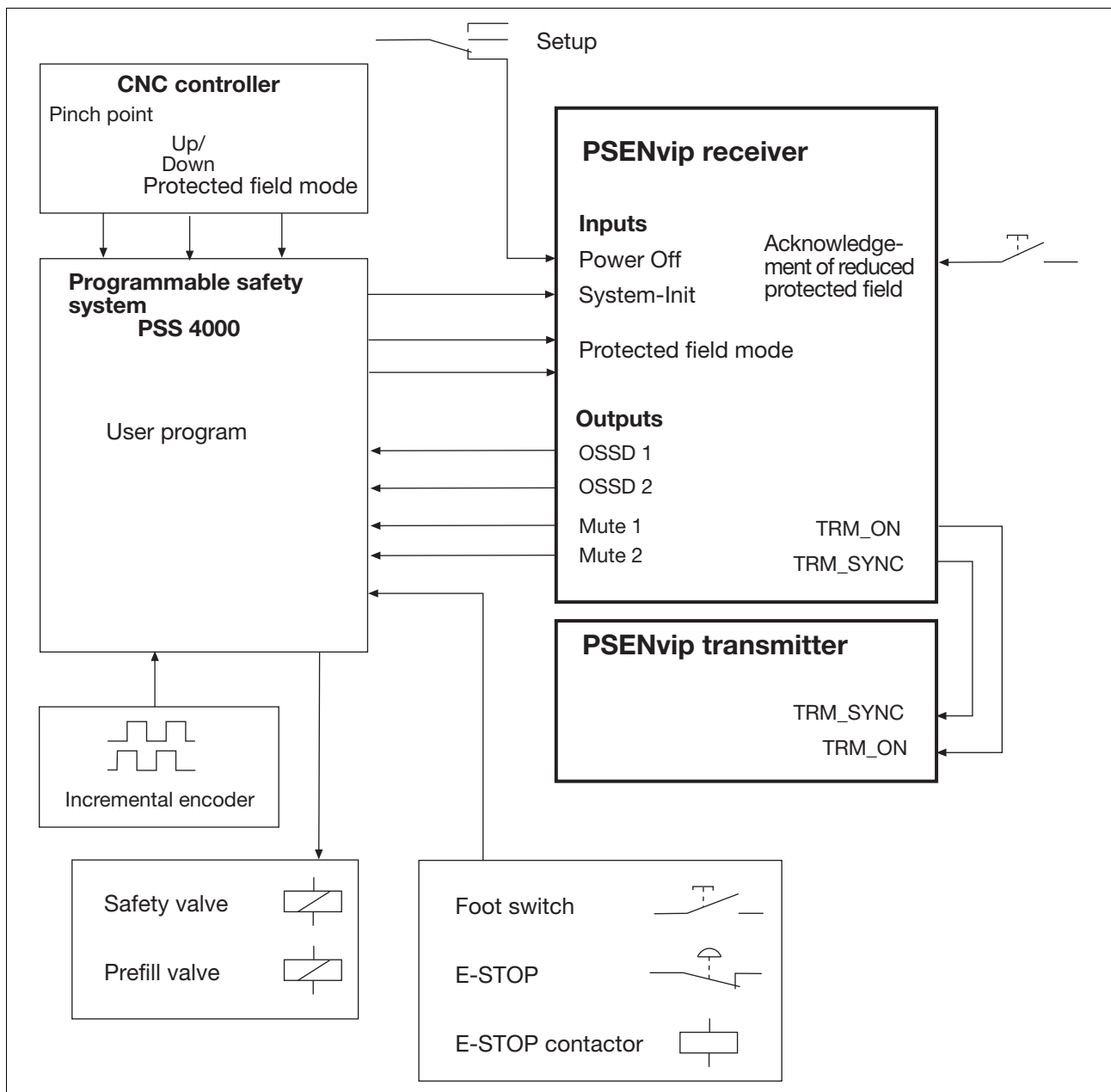

Fig. 4-2: Overview of overall system

4.1 Overview



INFORMATION

Some inputs and outputs on the receiver are also used for communication with the safety system (see section entitled "Communication with the safety system"). If communication is not required, protected field mode can also be controlled directly via the CNC controller.

The motion sequence of the press is monitored by the automation system PSS 4000. In the PSS 4000 user program safety functions must be implemented to safeguard the dynamic muting of PSEnvip. (see chapter 10 "System Connections").

The receiver evaluates the parallel beams generated by the transmitter. The beam is enclosed by the illuminated target area. The lens on the receiver only detects light that runs parallel to the optical axis. This guarantees stability against diffused light.



WARNING!

The light generated by the transmitter is not hazardous to the human eye.

However, do not use additional optical aids, e.g. lenses, to look at the light from the transmitter. This could damage the eye.

The receiver monitors and evaluates the detection zone between the transmitter and receiver. The protected field is the cross section of the detection zone. It consists of several segments.

4.1 Overview

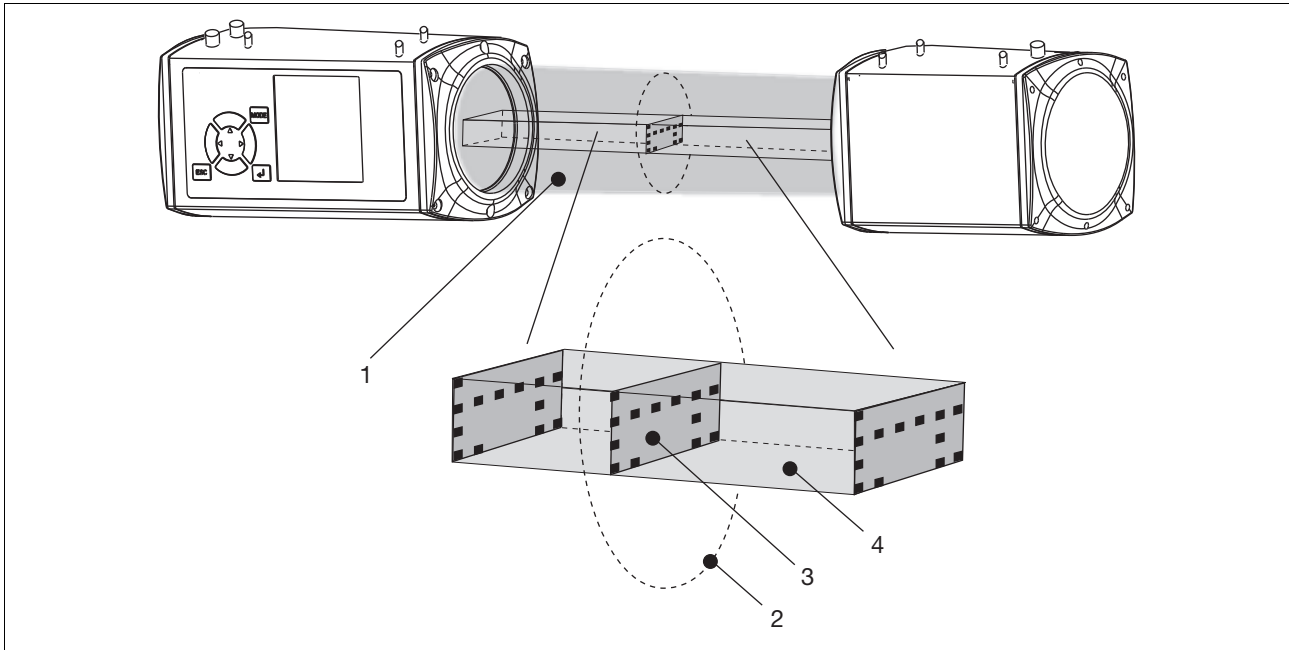

Fig. 4-3: Definitions

Key:

- ▶ 1: Light beam bundle
- ▶ 2: Illuminated target area
- ▶ 3: Protected field
- ▶ 4: Detection zone

The shape and size of the protected field depend on the bending function and the machine-dependent overrun. A reduced protected field is possible for box bending and/or back gauge mode (for the size of the protected field please see "Protected field" section and the chapter entitled "Technical Details").

If an object encroaches into the detection zone, both output signal switching devices (OSSD1 and OSSD2) on the PSEnvip will switch to the OFF-state. The safety system will use these signals to initiate stopping of the press stroke.

4.2 Protected field

The protected field consists of several segments. The front and rear segments (viewed from the operator's side) can be deactivated. This provides flexibility to adapt to the bending function:

- ▶ Standard
 - Full protected field: all segments active
- ▶ Box bending
 - Reduced protected field: front segments deactivated
- ▶ Bending with back gauge
 - Reduced protected field: rear segments deactivated
- ▶ Box bending with back gauge
 - Reduced protected field: front and rear segments deactivated

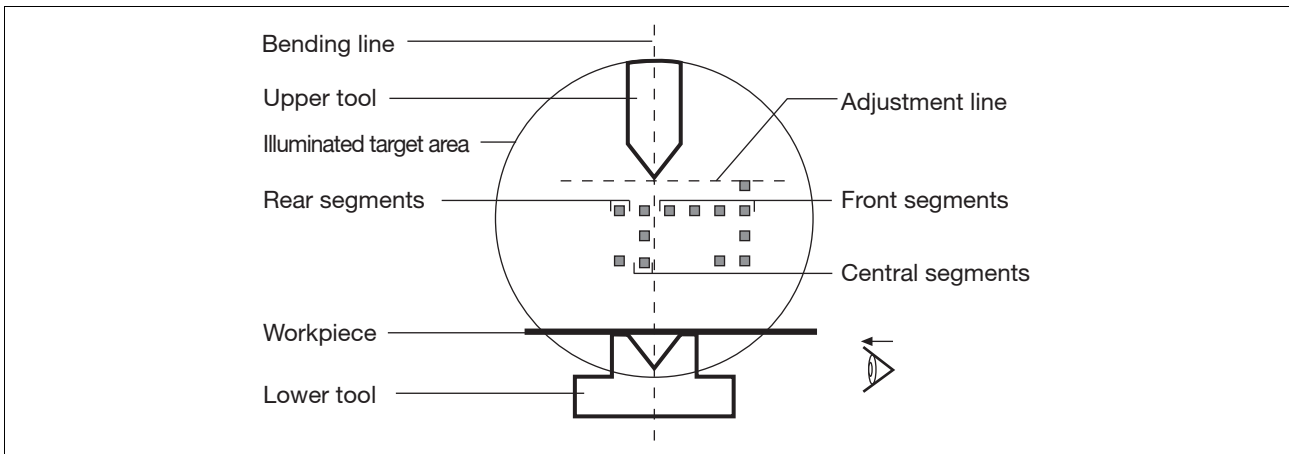

Fig. 4-4: Protected field definitions

The height of the protected field depends on the overrun. For the setting range of the overrun please see following figure and Chapter 11, "Technical Details".

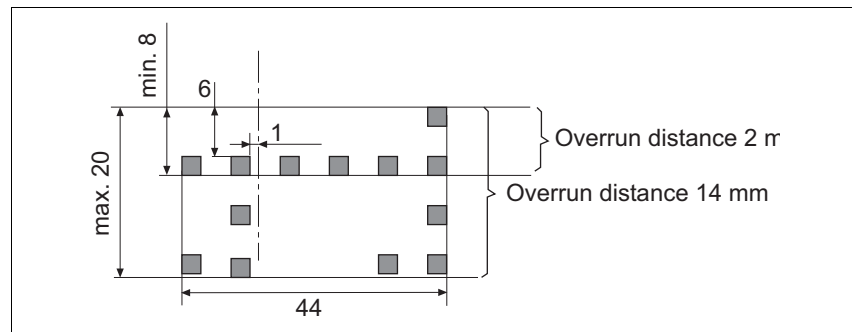

Fig. 4-5: Size of the detection zone

4.2 Protected field



INFORMATION

Please note that the central segments are 1 mm behind the bending line. With box bending you must ensure that the side panels of the box do not encroach into this area.

The two following sections explain the basic mode of action of the protected field during a press stroke (interrupted and uninterrupted).



INFORMATION

The cycle of a press stroke with the corresponding inputs and outputs is explained in this chapter, in the section entitled "System cycle".

4.2.1 Dynamic muting

An advance measuring field is located below the protected field. If is interrupted, the dynamic muting is started. The dynamic muting ensures that the danger zone between upper tool and plate is monitored up to a remaining gap of 6 mm during the downward movement.

The distance of the advance measuring field to the lower edge of the protected field is constant. The distance to the top edge of the protected field varies according to the length of the overrun.

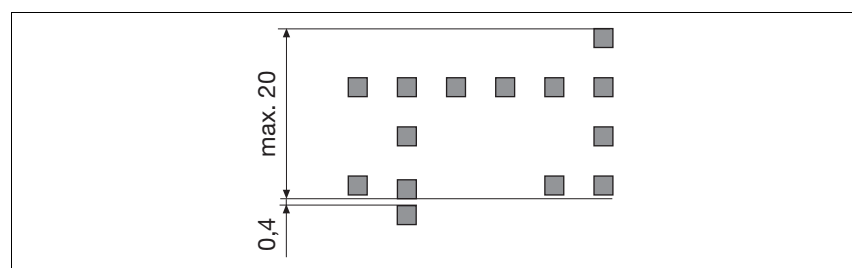

Fig. 4-6: Distance of advance measuring field from protected field

Procedure:

1. The press is on downward movement. The protected field moves down with the upper tool.
2. The advance measuring field touches the workpiece. The outputs Mute1 and Mute2 at the receiver are set = 0.

4.2 Protected field

3. The advance measuring field is used to hold the protected field stationary at the pinch point on the workpiece. The segment division is optimised for the dynamic muting process.
4. The respective upper segments are deactivated before the upper tool enters the protected field.



NOTICE

The control system may only override the safety function from a remaining gap of 6 mm.

Signal statuses of the outputs Mute1/Mute2 and OSSD1/OSSD2

<p>full protected field active</p> <p>OSSD1/ OSSD2 = 1 Mute1/Mute2 = 1</p>	
<p>full protected field active advance measuring field touches plate</p> <p>OSSD1/ OSSD2 = 1 Mute1/Mute2 = 1 -> 0</p>	
<p>Remaining gap = 6mm</p> <p>OSSD1/ OSSD2 = 1 -> 0 Mute1/Mute2 = 0</p>	

4.2 Protected field

The signal statuses of the outputs Mute1/Mute2 and OSSD1/OSSD2 when interrupting the protected field by side intervention or interruption of the advance measuring field before reaching the plate are described in section entitled "Standard interrupted press stroke".

4.2.2 Standard interrupted press stroke

It is necessary to distinguish between

- ▶ Interruption of the advance measuring field

and

- ▶ Side intervention with full protected field and reduced protected field during the dynamic muting

Interruption of the advance measuring field

<p>1 Downward movement Object interrupts advance measuring field, starts dynamic muting</p> <p>OSSD1/OSSD2 = 1 Mute1/Mute2 = 1 -> 0</p> <p>Safety system initiated the stopping of the press, measuring field was not interrupted in the expected position (pinch point)</p>	
<p>2 Upper tool continues moving for the overrun distance. Protected field interrupted. Object is removed. Protected field cleared. Press stroke can be resumed.</p>	

4.2 Protected field

Side intervention with full protected field or reduced protected field during the dynamic muting

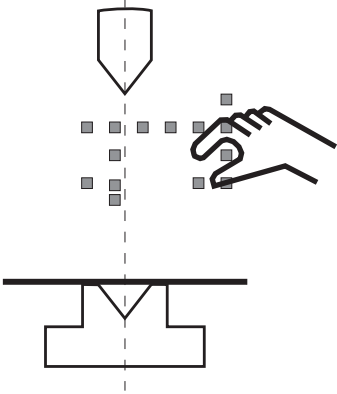
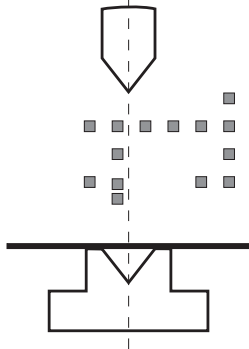
<p>1 Object interrupts the protected field to the side:</p> <p>OSSD1/OSSD2= 1 -> 0 Mute1/Mute2 = 1</p> <p>Safety system initiates the stopping of the press stroke</p>	
<p>2 Upper tool continues moving for the overrun distance. Protected field interrupted. Object is removed. Protected field cleared. Press stroke can be resumed.</p>	

4.3 Overrun

The max. overrun is a press brake variable that will depend on the machine type. Once the closing movement has stopped, the max. overrun must not be exceeded.

The overrun is entered during configuration via the keypad on the PSEnvip receiver.



INFORMATION

Please refer to chapter 11, "Technical Details", for more information about the input area of the overrun.

Details on how to enter the overrun are described in Chapter 7, "Commissioning", section entitled "Enter overrun".

Normally, the factory-assigned overrun is sufficient and does not have to be configured.



WARNING!

If you require a different overrun path than the factory-set path, then use the value indicated by the manufacturer on the nameplate of the press brake, or a higher value.

If you enter a lower value for the overrun, the protected field will also be reduced to an unpermitted level.

Failure to comply could result in a **hazardous situation**, which could lead to **serious injury and death**.

4.4 Description of the units

4.4.1 Overview

The transmitter and receiver form one unit. The receiver contains all the inputs and outputs required for communication with the CNC controller, programmable safety system, transmitter and press brake. The transmitter merely contains the inputs for controlling the light source.

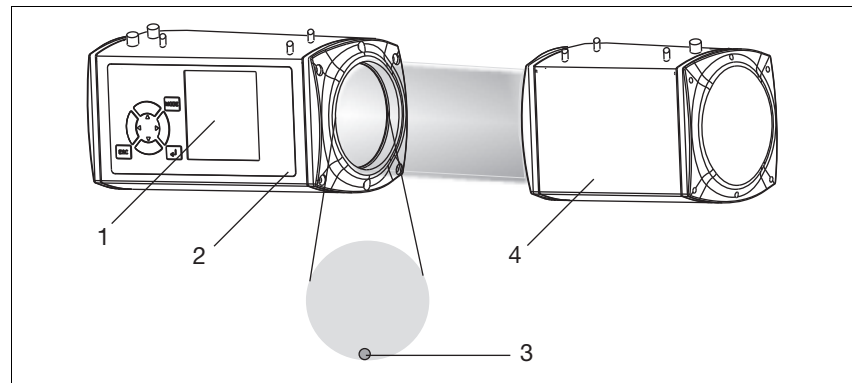

Fig. 4-7: Transmitter and receiver

- ▶ 1: Display
- ▶ 2: Receiver
- ▶ 3: LED: OSSD status
- ▶ 4: Transmitter

4.4.2 Transmitter

The top of the transmitter has a 4-pin M12 connector.

4.4.2.1 Inputs

The receiver uses these standard inputs to control the transmitter's light source. The user cannot influence these internal signals.

▶ **TRM_ON**

The receiver uses this signal to switch the transmitter's light source on and off.

▶ **TRM_SYNC**

The receiver uses this signal to control the intensity of the transmitter's light source.

4.4 Description of the units

4.4.3 Receiver

The top of the receiver has two 8-pin M12 connectors.

4.4.3.1 Inputs

▶ System-Init

Input whose signal comes from the safety system PSS 4000.

System-Init = 1: Press at top dead centre or in an upward movement

System-Init = 0: Downward movement

The PSEnvip can perform internal availability tests and completely activate the protected field when System-Init = 1. The outputs OSSD and mute are in the OFF state (OSSD = 0, Mute = 0).



INFORMATION

Please note that the PSEnvip independently carries out an internal safety test every 2 minutes, if such a test is not requested within this time by an external control system through System-Init = 1. The PSEnvip switches the OSSDs off during the safety tests. For this reason you should ensure that the safety tests are requested by an external control system before these 2 minutes have elapsed. The best time to do this is when the OSSDs are already switched off due to the position within the press stroke, e.g. at top dead centre.

▶ Power Off

Input signalling that the press brake is in setup mode.

Power Off = 1: Setup mode activated

All safety functions are deactivated in setup mode.

- The display is switched on.
- The **OSSD** LED on the receiver lights up red.
- The light source is switched off.



INFORMATION

The Power Off input has another function during the system status TEST. It is used for communication with the safety system. See "Communication with a safety system" in this section.

4.4 Description of the units

▶ **Acknowledgement**

Input to acknowledge that a press stroke is to be performed with a reduced protected field (front and/or rear segments blanked). The protected field mode selected is shown on the receiver's display. Acknowledgement = 0/1 pulse edge via pushbutton: Run selected protected field mode

▶ **Protected field mode 1/protected field mode 2**

Two safe inputs for setting the protected field mode. The CNC or safety system provides the signal. It is only absolutely necessary to connect the inputs to a safety system if communication is needed for tool detection.

Protected field mode		Bending function
1	2	
0	0	Standard
1	0	Box bending
0	1	Bending with back gauge
1	1	Box bending with back gauge



INFORMATION

The inputs for protected field mode have another function during the system status TEST. They are used for communication with the safety system. See "Communication with a safety system" in this section.

4.4 Description of the units

4.4.3.2 Outputs

- ▶ **OSSD1/OSSD2 in accordance with EN 61496-1, type 4**
Two safe outputs that signal the status of the protected field:
OSSD = 1: Protected field clear
OSSD = 0: Protected field broken
- ▶ **Mute1/Mute2 in accordance with EN 61496-1, type 4**
Two safe outputs that signal the dynamic muting
Mute1/Mute2 = 1: no dynamic muting
Mute1/Mute2 = 0: dynamic muting active



INFORMATION

The outputs Mute1/Mute2 have another function during the system status TEST. They are used for communication with the safety system. See "Communication with a safety system" in this section.



INFORMATION

For details of the output behaviour during a press stroke please refer also to the section entitled "System cycle", in this chapter.



INFORMATION

The outputs OSSD1/OSSD2 and Mute1/Mute2 are checked via regular output tests.

Output test

Outputs that are switched on are checked via regular off tests.

- ▶ Test pulses for outputs that are switched on: see Technical Details
- ▶ Outputs that are switched on are switched off for the duration of the test pulse.
- ▶ The load must not switch off because of the test.

Outputs that are switched off are checked via regular on tests.

- ▶ Test pulses for outputs that are switched off: see Technical Details
- ▶ Outputs that are switched off are switched on for the duration of the test pulse.

4.4 Description of the units

- ▶ The load must not switch on because of the test.

Testing for shorts

- ▶ A test is regularly carried out to check for shorts between the outputs.

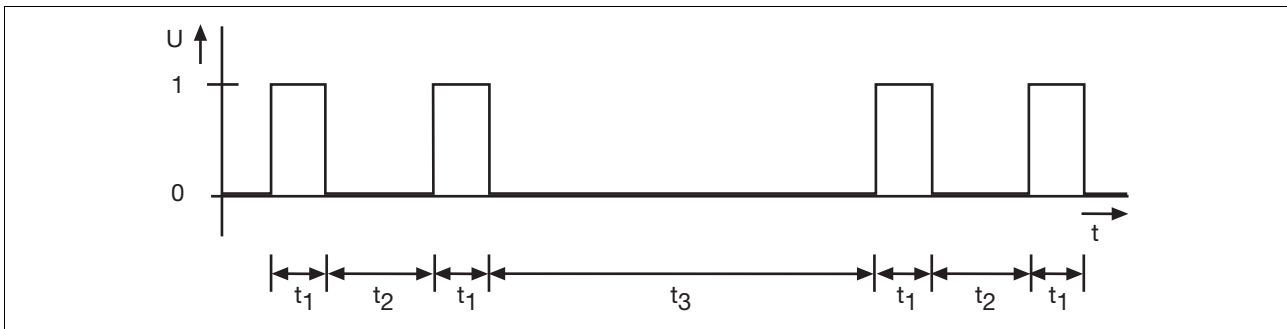

Fig. 4-8: Test pulses

Key:

- ▶ t_1 : Pulse length of on test (40 μ s)
- ▶ t_2 : Repetition length of on test (100 μ s ... 3 ms)
- ▶ t_3 : Cycle time of on test (30 μ s ... 5 min)



WARNING!

When wiring an output with capacitance it is essential to note the pulse duration, repetition period and scan time of the power-up test, otherwise the load may switch on unintentionally.

4.4 Description of the units

4.4.3.3 LED

► **OSSD**

The **OSSD** LED on the receiver indicates the status of the protected field.

Green: The protected field is clear

Red: Protected field is interrupted

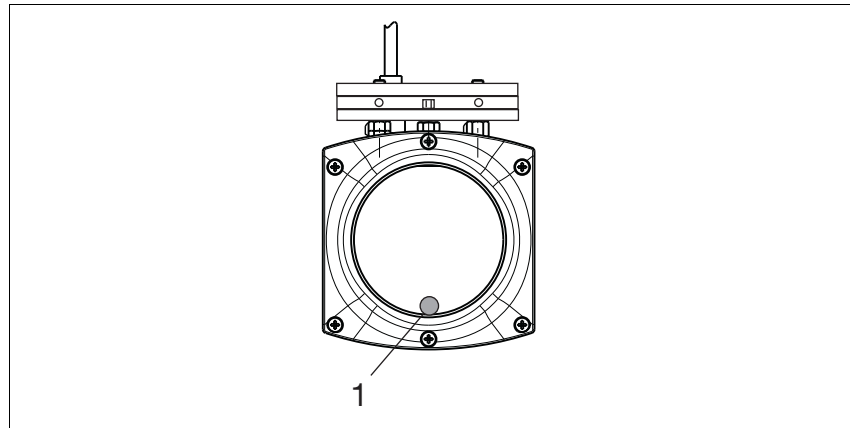

Fig. 4-9: LED on receiver

► 1: OSSD LED

4.4 Description of the units

4.4.3.4 Key display and function

The PSEnvip receiver has an integrated display. Data can be entered via a membrane keypad.

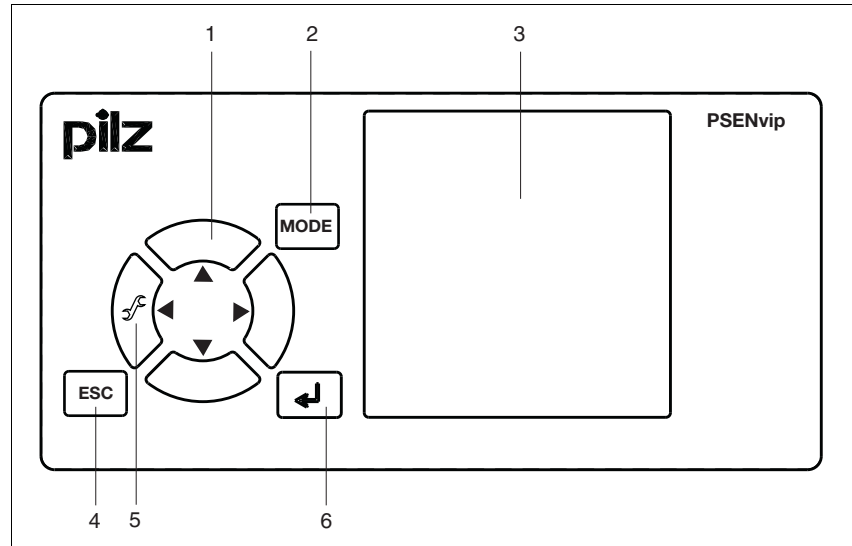

Fig. 4-10: Display on the receiver



Key:

- ▶ 1: Navigation keys
- ▶ 2: <MODE> key
- ▶ 3: Display
- ▶ 4: <ESC> key
- ▶ 5: Tool change
- ▶ 6: <ENTER> key

Key functions

Key	Description
▲ ▼	Move in the direction of the arrows (scroll function) (up/down)
◀▶	Confirm entry - together with the <ENTER> key when confirming the entered overrun and making adjustments during a tool change
MODE	Call up the operating modes: tool change and adjustment during initial commissioning. The DIAGNOSTICS menu is also available.
ESC	Close current window, cancel entry

4.4 Description of the units

Key	Description
	Call up tool change operating mode directly
	Confirm entry or menu option selection

Display

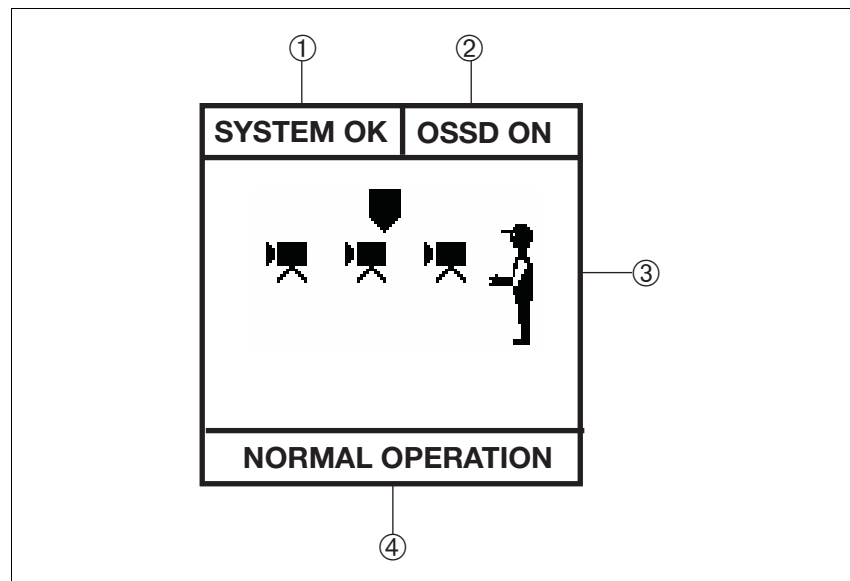

Fig. 4-11: Information on the display

The display is divided into 4 segments:

- ▶ 1: System status
- ▶ 2: Status of the OSSD
- ▶ 3: Input and display field
- ▶ 4: Operating status

4.4 Description of the units

System status

Status	Description
SYSTEM OK	The PSEnvip is performing the specified operating mode without error, see table: "Operating status"
TEST	The PSEnvip is performing calibration and internal tests.
STANDBY	The PSEnvip is deactivated when the press is in setup mode.
ERROR	An error has occurred (HOLD, STOP, FATAL). See Chapter 9, "Diagnostics and Troubleshooting"

Status of the OSSD

Status	Description
OSSD ON	The output signal switching devices OSSD1 and OSSD2 are in the ON state. The protected field is clear.
OSSD OFF	The output signal switching devices OSSD1 and OSSD2 are in the OFF state. The protected field is interrupted. Or the PSEnvip is not in the status: SYSTEM OK or NORMAL OPERATION

Operating state

State	Description
NORMAL OPERATION	One of the protected field modes is activated. See Chapter 8, "Operation"
SETUP	This is the operating mode in which you enter the overrun. See Chapter 7, "Commissioning"
TOOL CHANGE	This is the operating mode in which you track the adjustment line to the tip of the tool during a tool change. See Chapter 7, "Commissioning"
ADJUSTMENT	This is the operating mode in which you set up the transmitter and receiver mechanically so that they are calibrated with each other. See Chapter 7, "Commissioning"
DIAGNOSTICS	System data and error codes are displayed in this menu. Pilz technical support can use these to locate errors. See Chapter 9, "Diagnostics and Troubleshooting"
MENU	On pressing the <MODE> key, you can choose between the following options: - TOOL CHANGE: Adjustment during tool change - ADJUSTMENT: Adjustment during initial commissioning - DIAGNOSTICS: Display error codes

4.4 Description of the units

The input and display field is used to

- ▶ Display the active protected field mode
See chapter 8, "Operation"
- ▶ Enter the overrun
See chapter 7, "Commissioning"
- ▶ Menu Selection
- ▶ Display the adjustment image during initial commissioning
See chapter 7, "Commissioning"
- ▶ Display the adjustment image during a tool change
See chapter 7, "Commissioning"
- ▶ Display of error messages and system data
See Chapter 9, "Diagnostics and Troubleshooting"

4.4.4 Communication with the safety system

Communication between the PSEnvip and safety system is required if you use tools that cannot be safeguarded in compliance with the standards (see section entitled "Tool shapes", under "Safety"). This is the case with tool classes 2 and 3. User programs that do not support communication with the PSEnvip can be used if you only intend to safeguard tools of tool class 1. This is the case with older versions of the PSEnvip, for example.

Communication between the PSEnvip and the PLC safety system is conducted via digital inputs and outputs. Some inputs and outputs on the PSEnvip have another function compared to normal mode.

Communication only occurs in the system status TEST. This status is adopted

- ▶ After power-up.
- ▶ After a tool change.
- ▶ After a 0/1 pulse edge at the input System-Init.
- ▶ Periodically every 2 minutes.

4.4 Description of the units

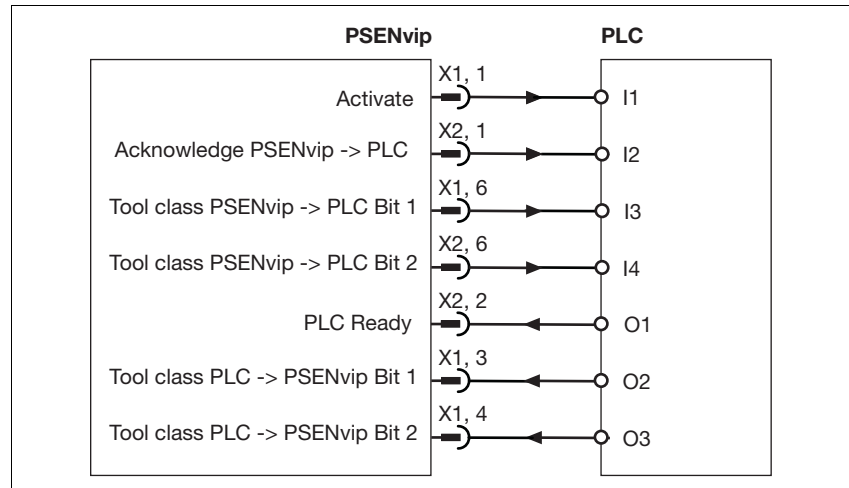

Fig. 4-12: Digital inputs and outputs for communication

Key to inputs and outputs:

Terminal	Input/output	Normal mode	Communication with safety system	Notes
X1, 1	Output	No function	Activate	The PSEnvip starts communication.
X2, 1	Output	No function	Acknowledge PSEnvip -> PLC	The PSEnvip confirms the validity of the tool class registered on the safety system.
X1, 6	Output	Mute1	Tool class PSEnvip -> PLC Bit 1	The PSEnvip sends Bit 1 of the detected tool class to the safety system.
X2, 6	Output	Mute2	Tool class PSEnvip -> PLC Bit 2	The PSEnvip sends Bit 2 of the detected tool class to the safety system.
X2, 2	Input	Power Off	PLC Ready	The safety system is ready for communication.
X1, 3	Input	Protected field mode 1	Tool class PLC -> PSEnvip Bit 1	The safety system reflects Bit 1 of the tool class.
X1, 4	Input	Protected field mode 2	Tool class PLC -> PSEnvip Bit 2	The safety system reflects Bit 2 of the tool class.

4.4 Description of the units

Communication sequence:

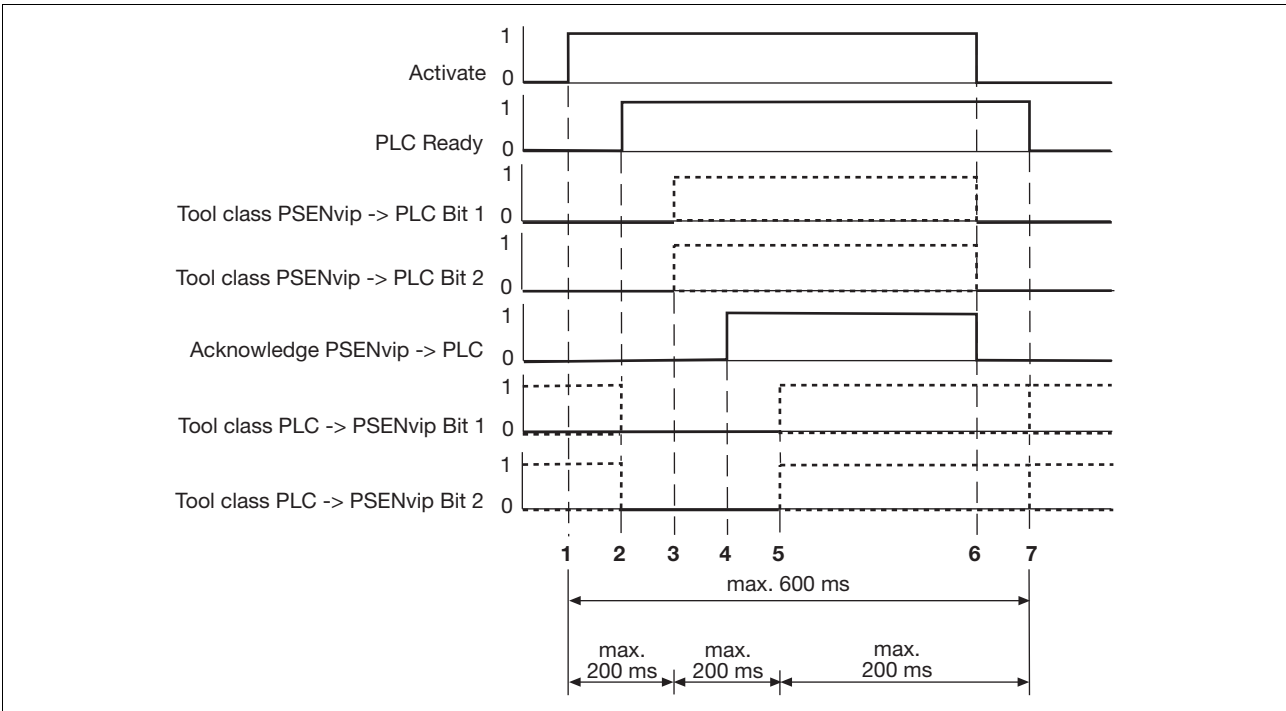

- ▶ **1**
 - The PSENvip starts communication.
Activate = 0/1 pulse edge
 - Tool class PLC -> PSENvip Bit 1/2: Bits can have any status
- ▶ **2**
 - The safety system is ready for communication.
PLC Ready = 0/1 pulse edge
 - Tool class PLC -> PSENvip Bit 1/2 = 0 to step 5
- ▶ **3**
 - The PSENvip sends the detected tool class to the safety system.

	Tool class		
	1	2	3
Tool class PSENvip -> PLC Bit 1	0	1	1
Tool class PSENvip -> PLC Bit 2	1	0	1

- ▶ **4**
 - The PSENvip confirms the validity of the tool class registered on the safety system in step 3.
Acknowledge PSENvip -> PLC = 0/1 pulse edge
- ▶ **5**
 - The safety system reflects the tool class transmitted by the PSENvip.
 - Tool class PLC -> PSENvip Bit 1/2 = 0 or 1, depending on the tool class

4.4 Description of the units

	Tool class		
	1	2	3
Tool class PLC -> PSEnvip Bit 1	0	1	1
Tool class PLC -> PSEnvip Bit 2	1	0	1

▶ **6**

The PSEnvip ends communication.

All outputs are set = 0:

- Activate = 0
- Acknowledge PSEnvip -> PLC = 0
- Tool class PSEnvip -> PLC Bit 1 = 0
- Tool class PSEnvip -> PLC Bit 2 = 0

▶ **7**

- The safety system ends communication.

PLC Ready = 1/0 pulse edge

- Tool class PLC -> PSEnvip Bit 1/2 = 0 or 1, depending on the original status



INFORMATION

The requirements of the user program in the safety system are described under "System Connections".

4.5 Protected field modes

Four protected field modes are available for adapting to different bending functions:

- ▶ Full protected field: Standard press stroke
- ▶ Reduced protected field:
 - Box bending press stroke
 - Back gauge press stroke
 - Box bending with back gauge press stroke

Use of the protected field modes depends on the tool class. Not all protected field modes can be selected with tool class 2 and 3.

Protected field mode	Tool class		
	1	2	3
Standard Full protected field	Yes	Yes	Yes
Box bending Front segments blanked	Yes	Yes	No
Back gauge Rear segments blanked	Yes	No	No

4.5.1 Standard protected field mode

The full protected field is available with standard protected field mode. This protected field mode is applied for flat workpieces.

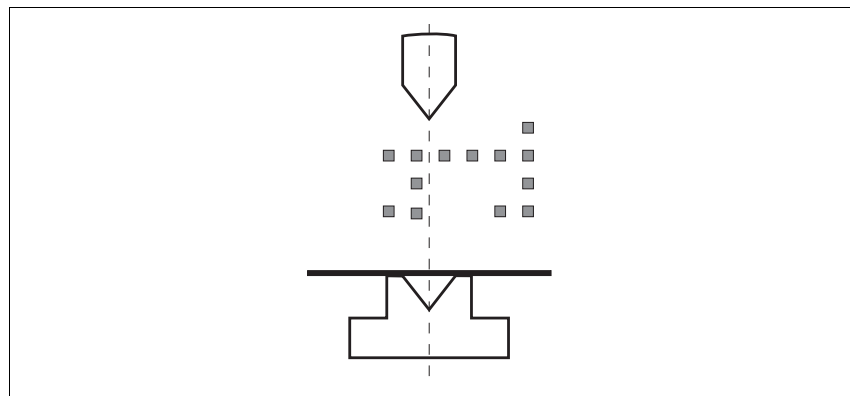

Fig. 4-13: Standard protected field mode

4.5 Protected field modes

4.5.2 Box bending protected field mode

With box bending protected field mode, the front segments of the protected field are blanked. This protected field mode is used for workpieces that need to be bent several times, e.g. a box. Interruption of the front segments is to be expected and does not cause the press stroke to stop.

The central segments of the protected field are behind the bending line. The box's side panels must not encroach into the central segments.

If the central or rear segments of the protected field are interrupted, the OSSDs switch to the OFF state.

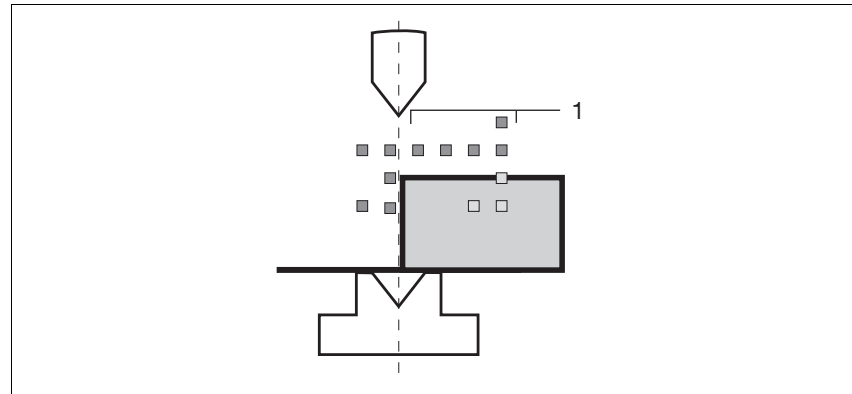

Fig. 4-14: Box bending protected field mode

- ▶ 1: Front segments of protected field are blanked

The box bending protected field mode is only active for one press stroke and must be acknowledged by the operator before it is initiated.



WARNING!

Crushing and trapping of fingers or hands!

With box bending protected field mode, the front segments of the protected field are blanked.

Around the bending line there is an increased risk of crushing and trapping of fingers or hands.

Make sure that the workpiece is handled correctly (see Chapter 3, "Safety").

4.5 Protected field modes

4.5.3 Back gauge protected field mode

With back gauge protected field mode, the rear segments of the protected field are blanked. This protected field mode is used when the rear back gauge extends into the vicinity of the bending line. Interruption of the rear segments is to be expected and does not cause the press stroke to stop.

If the front and central segments of the protected field are interrupted, the OSSDs switch to the OFF state.

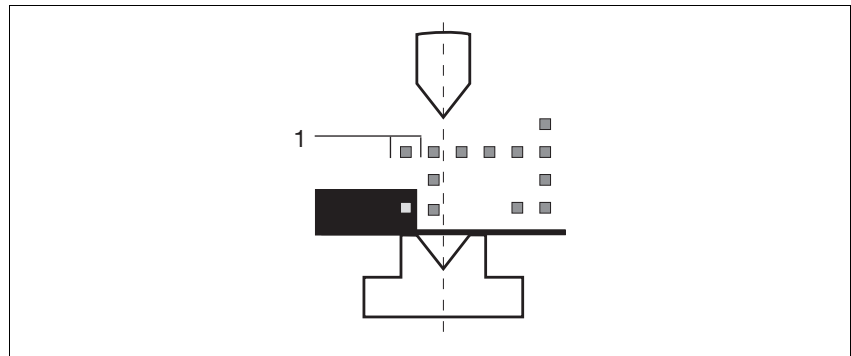

Fig. 4-15: Back gauge protected field mode

- ▶ 1: Rear segments of protected field are blanked

The back gauge protected field mode is only active for one press stroke and must be acknowledged by the operator before it is initiated.



WARNING!

Crushing and trapping of fingers or hands!

With back gauge protected field mode, the rear segments of the protected field are blanked.

Around the bending line there is an increased risk of crushing and trapping of fingers or hands.

Make sure that the workpiece is handled correctly (see Chapter 3, "Safety").

4.5 Protected field modes

4.5.4 Box bending with back gauge protected field mode

With box bending with back gauge protected field mode, both the rear and front segments of the protected fields are blanked. This protected field mode is applied for workpieces that need to be bended several times, e.g. boxes, and when the rear back gauge extends into the vicinity of the bending line. Interruption of the front and rear segments is to be expected and does not cause the press stroke to stop.

The central segments of the protected field are behind the bending line. The box's side panels must not encroach into the central segments.

If the central segments of the protected field are interrupted, the OSSDs switch to the OFF state.

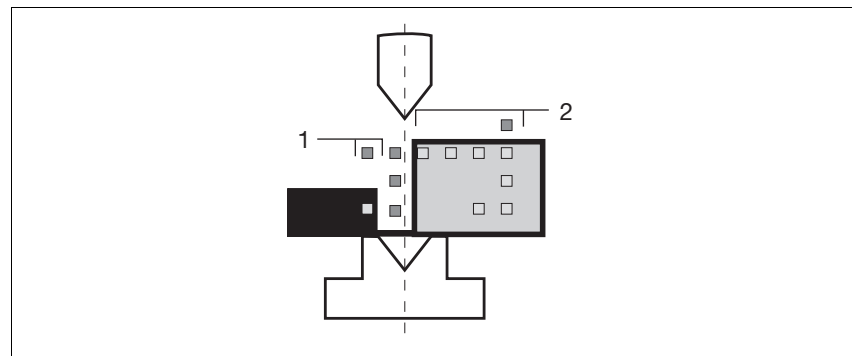

Fig. 4-16: Box bending with back gauge protected field mode

- ▶ 1: Rear segments of protected field are blanked
- ▶ 2: Front segments of protected field are blanked

The box bending with back gauge protected field mode is only active for one press stroke and must be acknowledged by the operator before it is initiated.



WARNING!

Crushing and trapping of fingers or hands!

With box bending with back gauge protected field mode, both the front and rear segments of the protected fields are blanked. Around the bending line there is an increased risk of crushing and trapping of fingers or hands.

Make sure that the workpiece is handled correctly (see Chapter 3, "Safety").

4.6 Operating modes during commissioning

The PSEnvip has the following options for commissioning:

- ▶ Press brake setup mode
- ▶ Adjustment during initial commissioning
- ▶ Adjustment during tool change

4.6.1 Press brake setup mode

Setup mode must be activated when work is to be carried out on the press brake. The transmitter and receiver must be switched off. The display is switched on. By switching off the transmitter's light source the tool setter has visual communication that there is no safety function via the protected field. The **OSSD** LED on the receiver lights up red.

The input Power Off = 1 switches off the transmitter's light source.

4.6.2 Adjustment during initial commissioning

The transmitter and receiver are aligned to each other during initial commissioning. The vertical and horizontal alignment is performed using templates and is displayed on the receiver.

In this operating mode

- ▶ The protected field is inactive.
- ▶ The OSSDs are switched off.
- ▶ There is no protection via the PSEnvip.



INFORMATION

Details of the adjustments made during initial commissioning are described in Chapter 7, "Commissioning", section entitled "Initial commissioning".

4.6.3 Adjustment during tool change

The tool is assigned to a tool class in "Tool change" operating mode. Once the tool data has been saved it is downloaded to the safety system.

The adjustment line is automatically tracked to the tip of the tool. The tracking is shown on the display. This makes it easier to adjust to the different tool sizes.

4.6 Operating modes during commissioning



INFORMATION

Generally you should not have to mechanically realign the transmitter and receiver during a tool change.

In this operating mode

- ▶ The protected field is inactive.
- ▶ The OSSDs are switched off.
- ▶ There is no protection via the PSEnvip.



INFORMATION

Details of the adjustments made during a tool change are described in Chapter 7, "Commissioning", section entitled "Adjustment during tool change".

4.7 System cycle

This section illustrates the interdependencies of the parameters on the press brake, PSEnvip and safety system during a press stroke. The following parameters are illustrated:

- ▶ Status: Describes the cycle status. The upward movement of the press is assumed as a safe movement.
- ▶ Foot switch: Start/stop press stroke
- ▶ System-Init: Press brake is at top dead centre
- ▶ OSSD: Output signal switching devices of the PSEnvip
- ▶ Protected field: Free, interrupted
- ▶ Mute 1/2: signals whether dynamic muting is activated or deactivated.

Mute 1/2 are reset to "1" when the protected field is completely activated and the advance measuring field is free.

A protected field that has already been partly deactivated can be completely reactivated by

- side intervention
- the signal System-Init = 1
- ▶ Dynamic muting:
 - reset: advance measuring field touches pinch point on the work-piece
 - End: Tool centre point reaches the 6 mm point

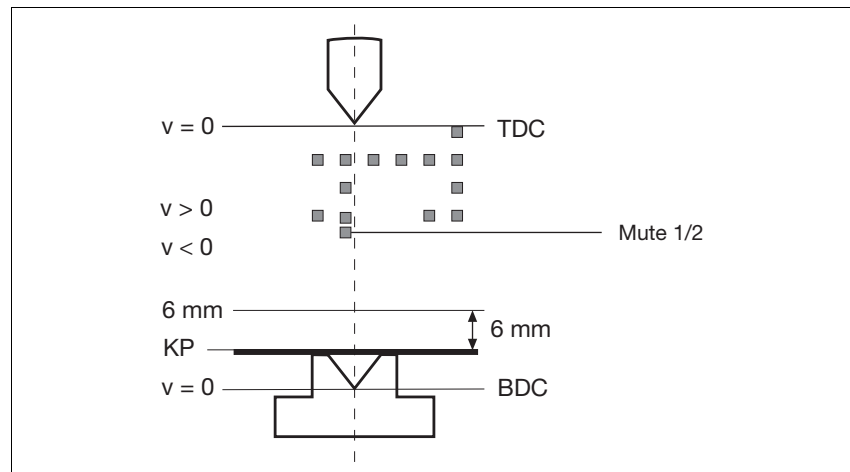

Fig. 4-17: Definitions

Legend:

- ▶ TDC top dead centre
- ▶ 6 mm: 6 mm point, end of dynamic muting
- ▶ PP: Pinch point
- ▶ BDC bottom dead centre
- ▶ $v = 0$ mm/s closing speed at top/bottom dead centre
- ▶ $v > 0$ mm/s downward movement

4.7 System cycle

- ▶ $v > 0$ mm/s upward movement
- ▶ Mute 1/2: Segment switches outputs Mute 1 and Mute 2

4.7.1 System cycle for standard press stroke

Inputs on the PSEnvip receiver:

- ▶ Protected field mode 1 = 0
- ▶ Protected field mode 2 = 0
- ▶ Power Off = 0

1

Status	Press is at top dead centre
Foot switch	0
System-Init	1
OSSD	0
Protected field	Free
Mute 1/2	0
Dynamic muting	Inactive

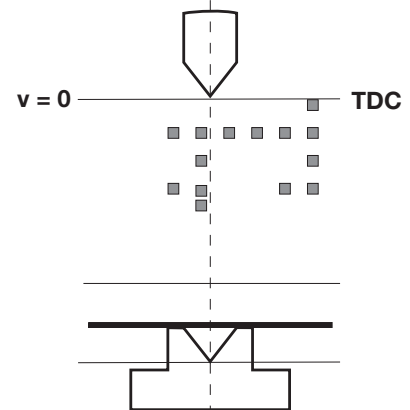

2

Status	Downward movement
Foot switch	1
System-Init	0
OSSD	1
Protected field	Free
Mute 1/2	1
Dynamic muting	Inactive

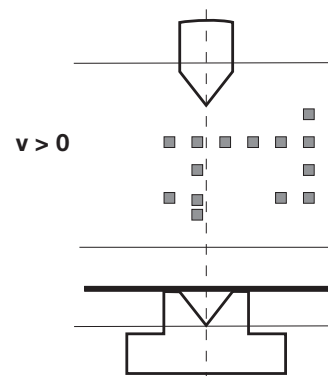

4.7 System cycle

3

Status	Downward movement Advance measuring field touches plate (pinch point)
Foot switch	1
System-Init	0
OSSD	1
Protected field	Free
Mute 1/2	1 -> 0
Dynamic muting	Start

$v > 0$

KP

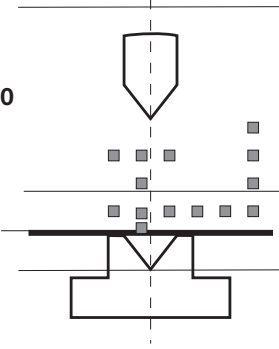

4

Status	Downward movement Tool centre point reaches the 8 mm point
Foot switch	1
System-Init	0
OSSD	1
Protected field	Free
Mute 1/2	0
Dynamic muting	Active

$v > 0$

KP

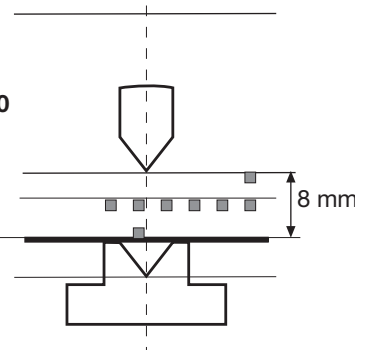

5

Status	Downward movement Tool centre point reaches the 6 mm point
Foot switch	1
System-Init	0
OSSD	1 -> 0 Muting of the OSSD in steps 5 to 8 in the safety system
Protected field	Interrupted
Mute 1/2	0
Dynamic muting	End

$v > 0$

6 mm

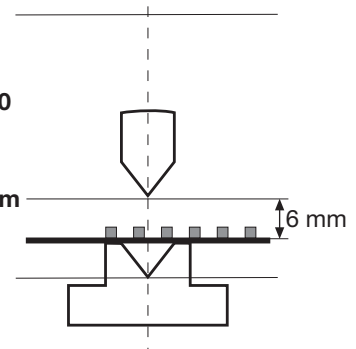

4.7 System cycle

6

Status	Downward movement
Foot switch	1
System-Init	0
OSSD	0
Protected field	Interrupted
Mute 1/2	0
Dynamic muting	Inactive

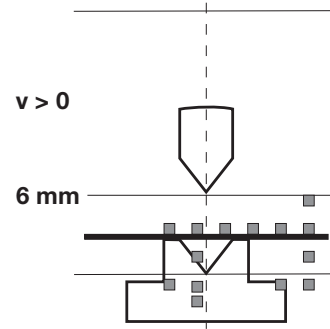

7

Status	Press is at bottom dead centre
Foot switch	1
System-Init	0
OSSD	0
Protected field	Interrupted
Mute 1/2	0
Dynamic muting	Inactive

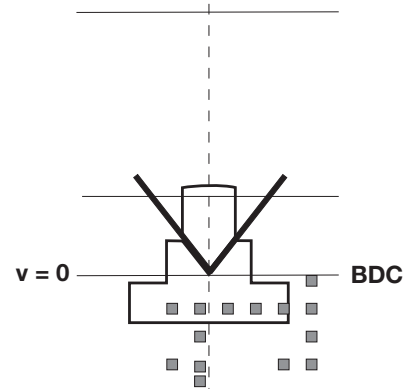

8

Status	Upward movement Advance measuring field is cleared
Foot switch	1 Generally, the press travels up automatically, the operator can release the foot switch.
System-Init	1
OSSD	1 or 0
Protected field	Free or interrupted
Mute 1/2	0 -> 1
Dynamic muting	Inactive

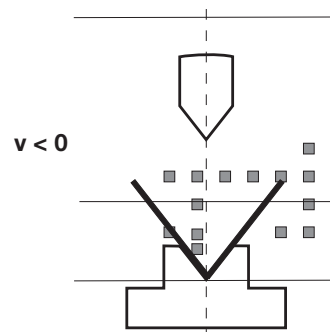

Continue with step 1

4.7 System cycle

4.7.2 System cycle for box bending press stroke

Inputs on the PSEnvip receiver:

- ▶ Protected field mode 1 = 0
- ▶ Protected field mode 2 = 1
- ▶ Acknowledgement of reduced protected field = Press pushbutton and then release

1

Status	Press is at top dead centre
Foot switch	0
System-Init	1
OSSD	0
Protected field	Free
Mute 1/2	0
Dynamic muting	Inactive

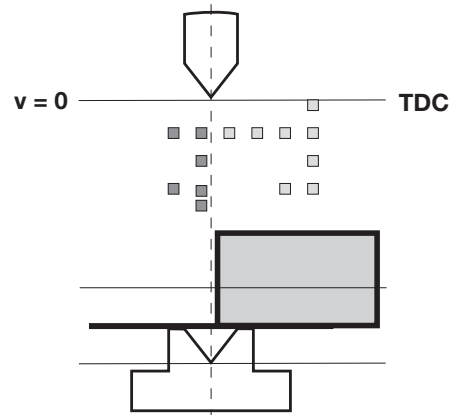

2

Status	Downward movement
Foot switch	1
System-Init	0
OSSD	1
Protected field	Free
Mute 1/2	1
Dynamic muting	Inactive

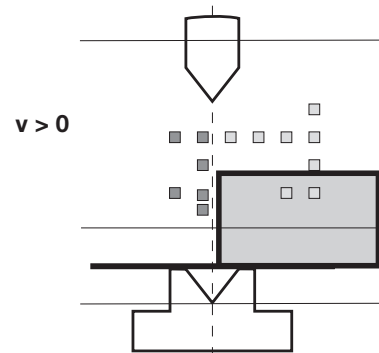

4.7 System cycle

3

Status	Downward movement Advance measuring field touches plate (pinch point)
Foot switch	1
System-Init	0
OSSD	1
Protected field	Free
Mute 1/2	1 -> 0
Dynamic muting	Start

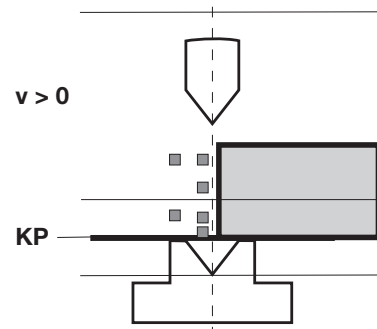

4

Status	Downward movement Tool centre point reaches the 8 mm point
Foot switch	1
System-Init	0
OSSD	1
Protected field	Free
Mute 1/2	0
Dynamic muting	Active

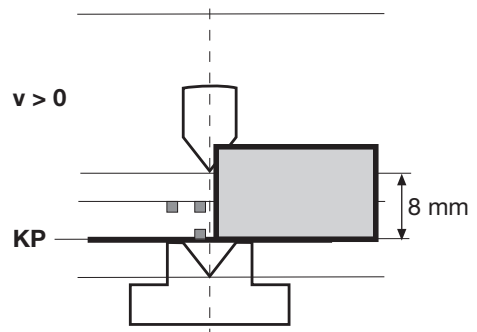

5

Status	Downward movement Tool centre point reaches the 6 mm point
Foot switch	1
System-Init	0
OSSD	1 -> 0 Muting of the OSSD in steps 5 to 8 in the safety system
Protected field	Interrupted
Mute 1/2	0
Dynamic muting	End

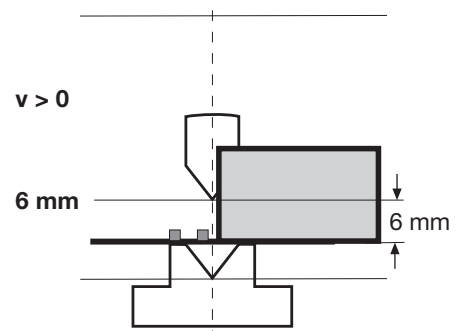

4.7 System cycle

6

Status	Downward movement
Foot switch	1
System-Init	0
OSSD	0
Protected field	Interrupted
Mute 1/2	0
Dynamic muting	Inactive

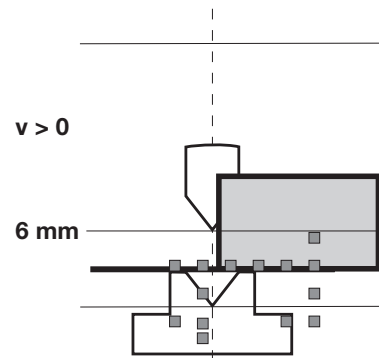

7

Status	Press is at bottom dead centre
Foot switch	1
System-Init	0
OSSD	0
Protected field	Interrupted
Mute 1/2	0
Dynamic muting	Inactive

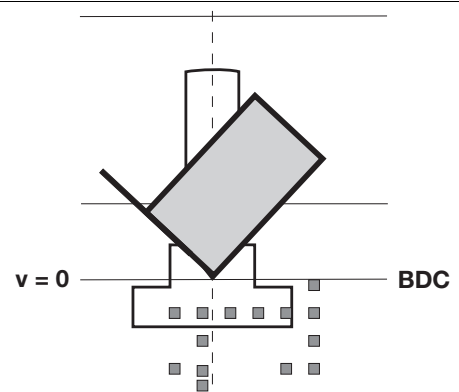

8

Status	Upward movement Advance measuring field is cleared
Foot switch	1 Generally, the press travels up automatically, the operator can release the foot switch.
System-Init	1
OSSD	1 or 0
Protected field	Free or interrupted
Mute 1/2	0 - > 1
Dynamic muting	Inactive

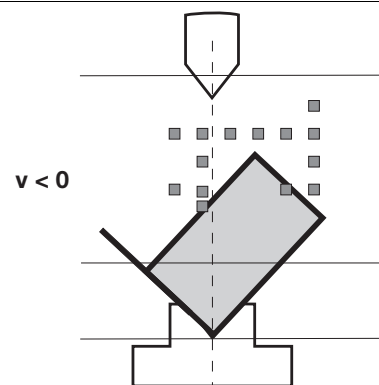

Continue with step 1

4.7 System cycle

4.7.3 System cycle for back gauge press stroke

Inputs on the PSEnvip receiver:

- ▶ Protected field mode 1 = 1
- ▶ Protected field mode 2 = 0
- ▶ Acknowledgement of reduced protected field = Press pushbutton and then release

The system cycle is the same as for box bending. Please note that with back gauge protected field mode, the rear segments of the protected field are blanked.

4.7.4 System cycle for box bending with back gauge press stroke

Inputs on the PSEnvip receiver:

- ▶ Protected field mode 1 = 1
- ▶ Protected field mode 2 = 1
- ▶ Acknowledgement of reduced protected field = Press pushbutton and then release

The system cycle is the same as for box bending. Please note that with box bending with back gauge protected field mode, both the front and rear segments of the protected field are blanked.

4 Function description

5.1 General requirements

Please note for installation:

- ▶ The PSEnvip may only be installed by qualified personnel.
- ▶ The environmental data for the PSEnvip must be taken into account. Details are available in the chapter entitled "Technical Details".
- ▶ The transmitter and receiver should be installed with the respective front lenses aligned in parallel to each other.
- ▶ The distance between the transmitter and receiver may not be greater than the value stated in the "Technical Details".



CAUTION!

Ensure that the field of vision of the front lenses on the transmitter and receiver is not restricted. Do not attach any other optical elements such as glass/plastic surfaces, films or lenses.

- ▶ Check the fastening of the PSEnvip at regular intervals.
- ▶ Check that the fastening of the PSEnvip is not accidentally working its way loose as a result of vibration from the press brake.

5.2 Install transmitter and receiver

- ▶ Fastening kits for the transmitter and receiver are available as accessories (for order no. see Chapter 11, "Technical Details").
- ▶ The fastening kit consists of an adapter plate and adjustment plate with a slot nut. The bracket on the upper die must have a corresponding groove in which to insert the slot nut (see Fig. 5-1).

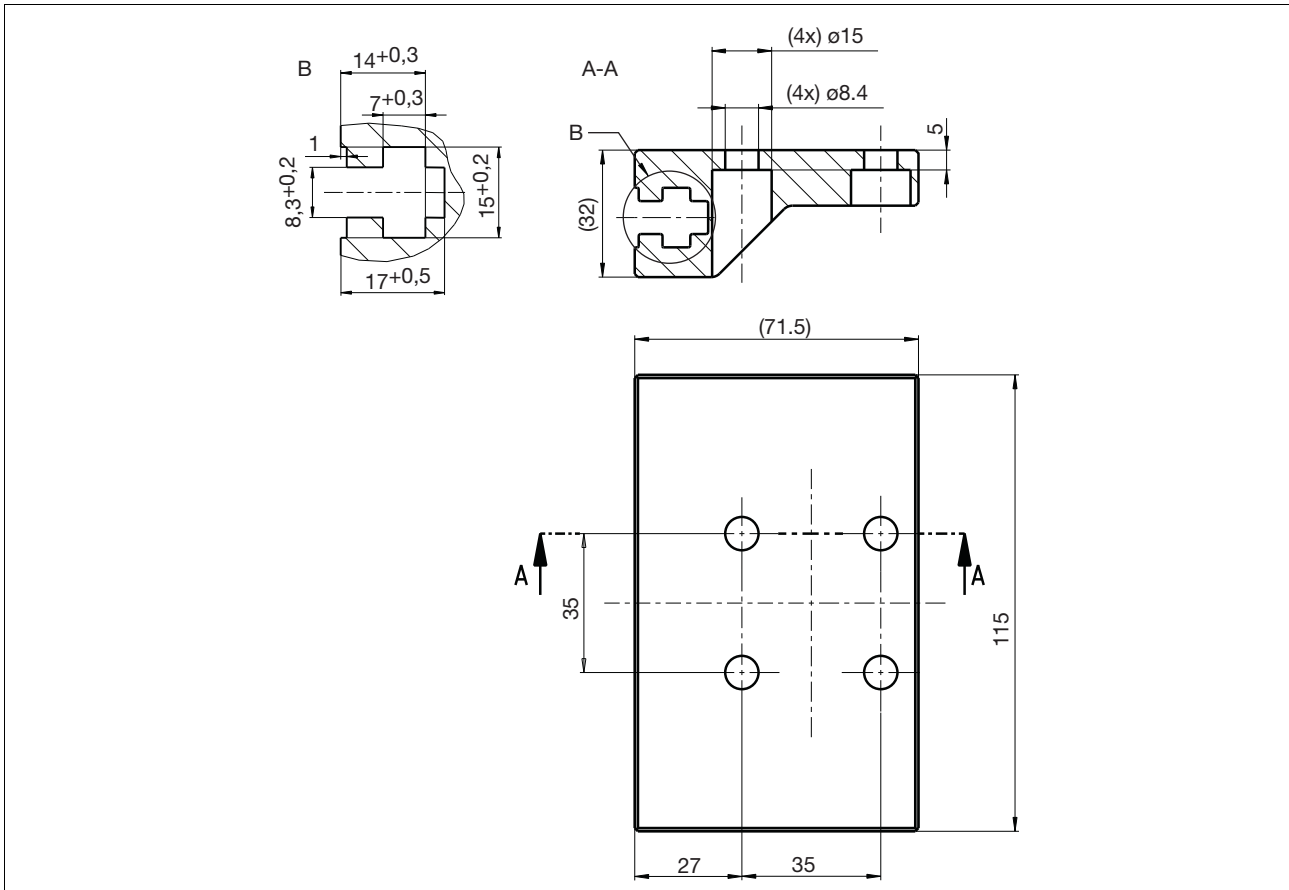

Fig. 5-1: Dimensions of adapter plate with groove, dimensions in mm

- ▶ Both the transmitter and receiver are installed in the same way. Only the dimensions of the adjustment plates for the transmitter and receiver are different.

To install the system, proceed as follows:

- ▶ Fasten the adjustment plate as shown in the diagram below. Ensure that the flat washers, spring washers and nuts are attached in the right order.

5.2 Install transmitter and receiver

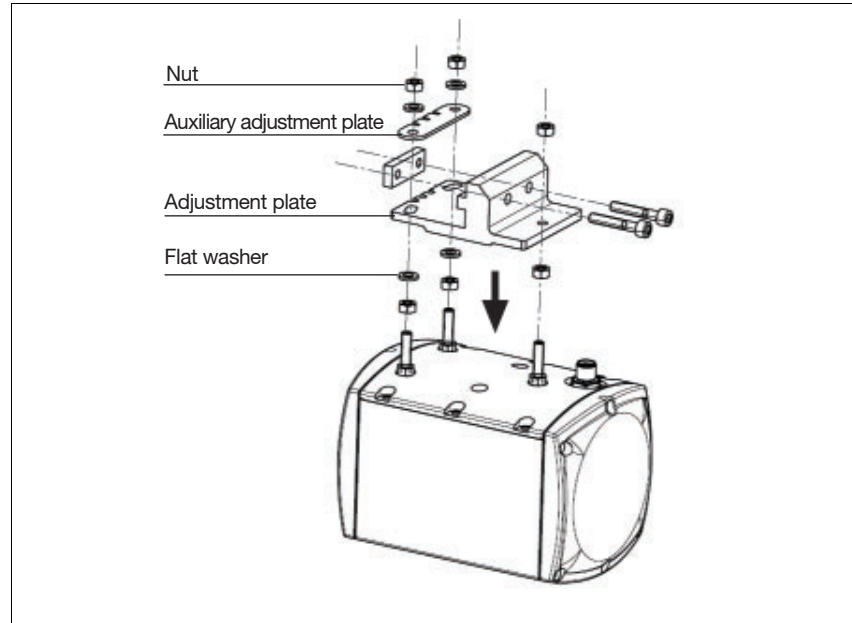

Fig. 5-2: Installing the transmitter and receiver

Viewed from the operator's side, the receiver is installed on the left-hand bracket and the transmitter on the right-hand bracket.

- ▶ Slide the nut slot on the adjustment plate into the groove on the bracket attached to the upper die.

5.3 Dimensions

5.3.1 Transmitter

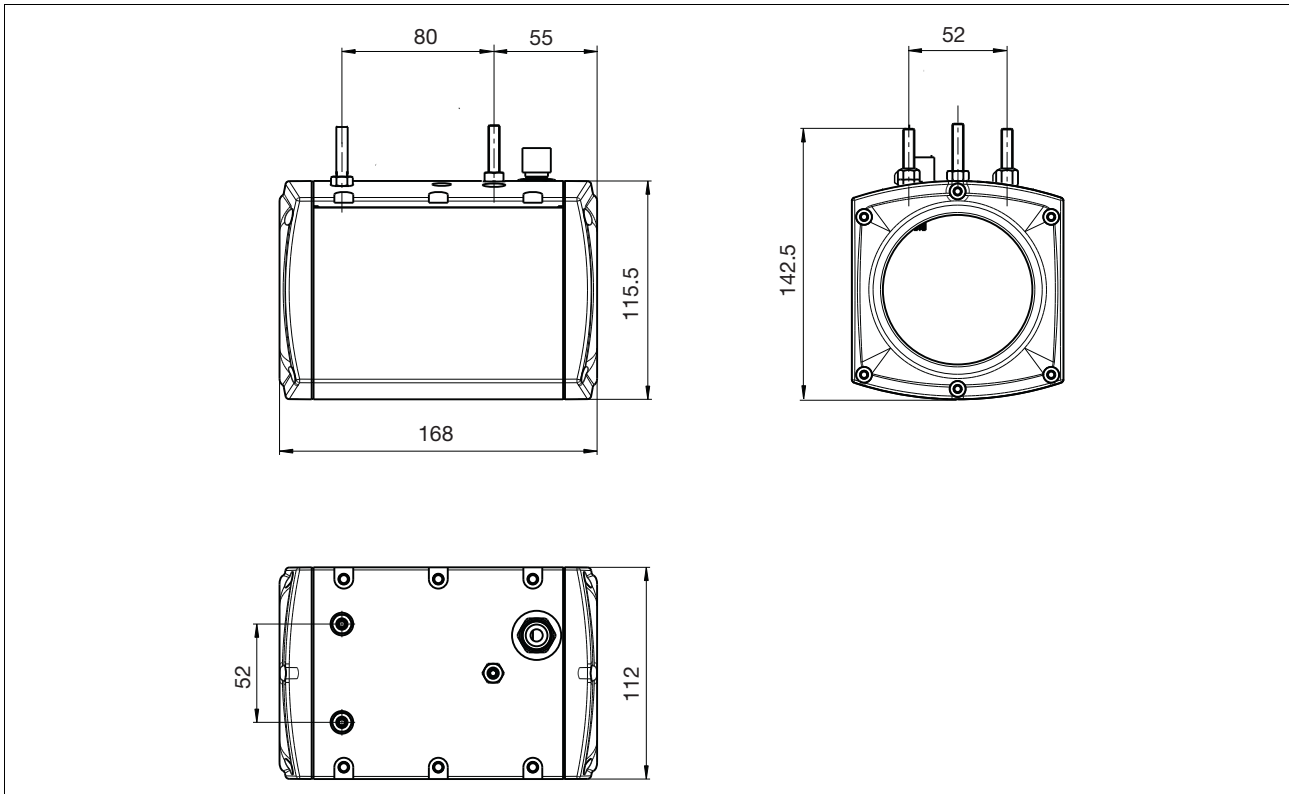

Fig. 5-3: Transmitter dimensions, dimensions in mm

5.3 Dimensions

5.3.2 Receiver

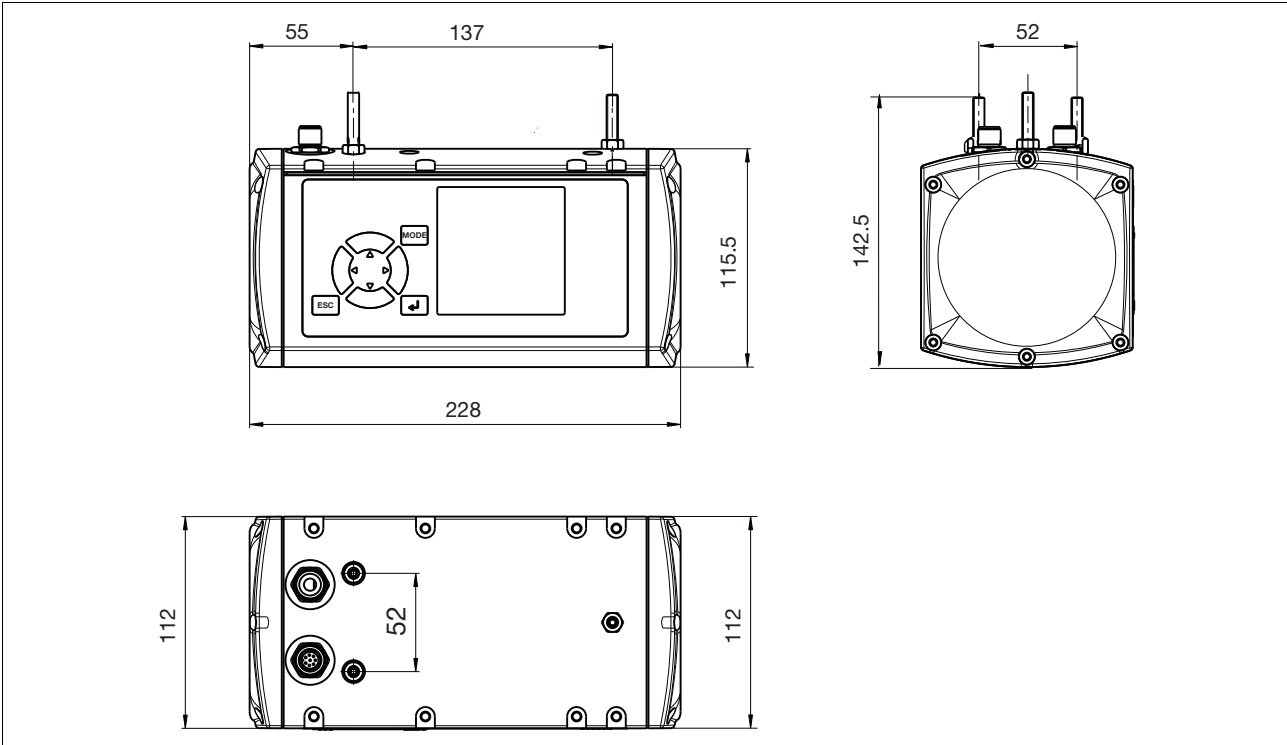

Fig. 5-4: Receiver dimensions, dimensions in mm

5.3.3 Fastening kit for the transmitter

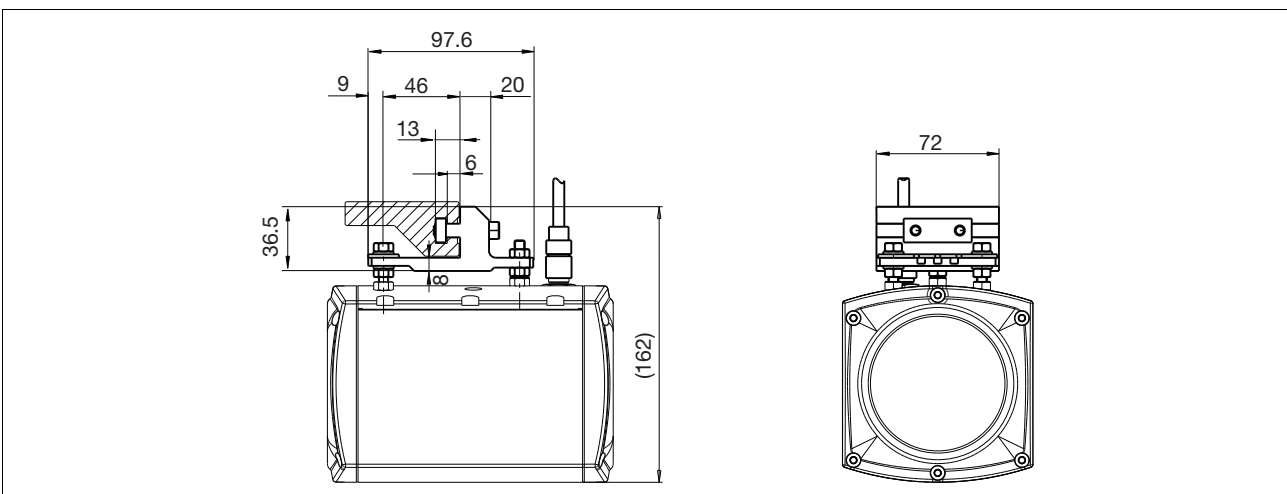

Fig. 5-5: Dimensions of the fastening kit for the transmitter, dimensions in mm

5.3 Dimensions

5.3.4 Fastening kit for the receiver

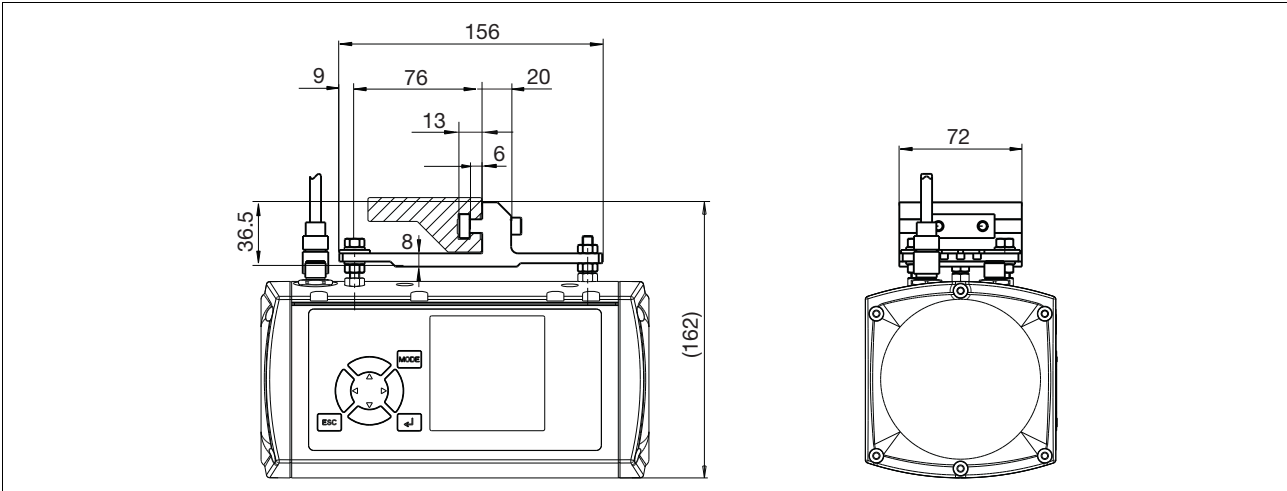

Fig. 5-6: Dimensions of the fastening kit for the receiver, dimensions in mm

5.3 Dimensions

5.3.5 Bracket for transmitter and receiver

- ▶ Brackets for the transmitter and receiver are available as accessories (for order no. see Chapter 11, "Technical Details").
- ▶ Details about installation can be found in the diagram below.

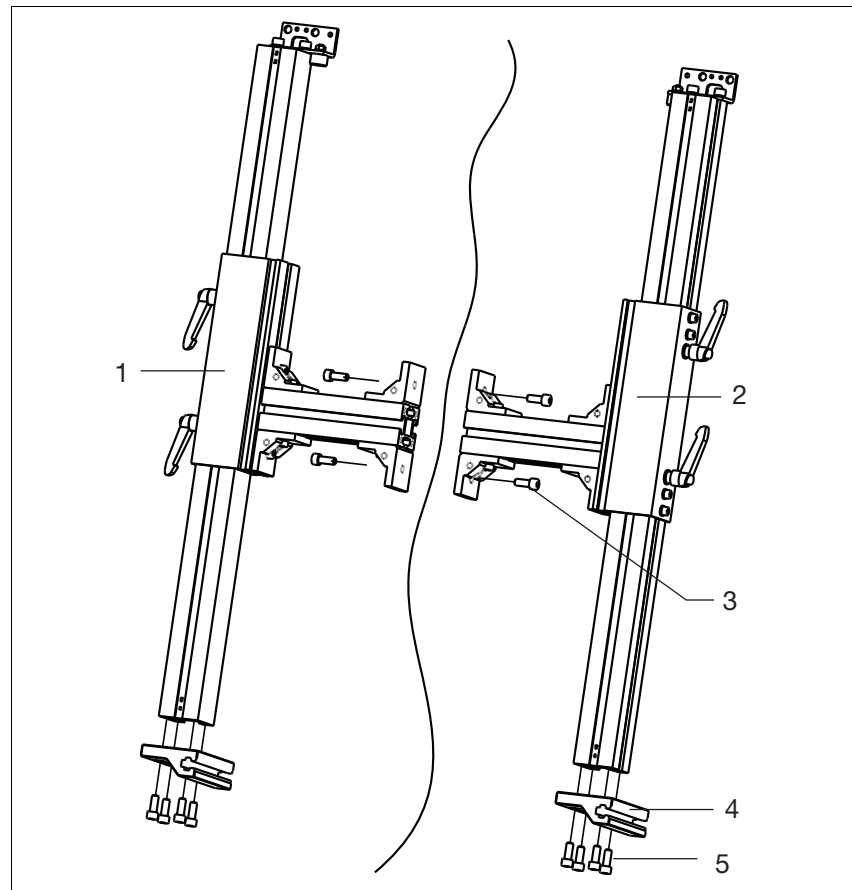

Fig. 5-7: Bracket for transmitter and receiver

Key:

- ▶ 1: left bracket
- ▶ 2: right bracket
- ▶ 3: 2 x DIN 912 M8x20 cheese head screw
- ▶ 4: adapter plate
- ▶ 5: 4 x DIN 912 M8x20 cheese head screw

6.1 Notes on wiring

Please observe the following when wiring:



CAUTION!

Unintended machine start up!

Voltage should be removed from the whole machine and PSEnvip during wiring.

Power supply

- ▶ When selecting the power supply, please refer to the requirements stated under “Technical Details”.
- ▶ The power supply used to supply the PSEnvip transmitter and receiver must be able to bridge a power outage of 10 ms. This requirement comes from EN 61496-1:2004: Safety of machinery – Electrosensitive protective equipment. Supply interruptions on the PSEnvip that cannot be bridged by the PSEnvip will always lead to a safe condition (OSSD1, OSSD2 in OFF condition).
- ▶ Overload protection must be provided. Use a circuit breaker with characteristic C, 4 A or 6 A, depending on the inrush current. Please refer to the recommendations of the power supply manufacturer.



WARNING!

Electric shock!

Safe electrical isolation must be ensured for the external power supply generating the 24 V supply voltage and the voltages to the inputs on the PSEnvip. Failure to do so could result in electric shock. The power supplies must comply with EN 60950-1 and EN 61558-2-6.

Cable

- ▶ The transmitter and receiver should only be connected using shielded cables (available as accessories). The cable shield is connected to the metal coupling on the M12 connectors.
- ▶ Earth the cable shield connection within the control cabinet, e.g. on a bus bar.
- ▶ The ready-made cables from Pilz should preferably be used for connecting The PSEnvip (see chapter 11, "Technical Details").
- ▶ Protect the cable from mechanical damage. Lay the cable in such a way that wire short circuits are excluded. If the cable is not protected through the machine, it should be laid in armoured hose.

6.1 Notes on wiring

EMC

- ▶ Avoid interference (e.g. from motors, power lines) by laying cables in a way that is EMC-compliant.

Inputs on the receiver

- ▶ The inputs **Protected field mode 1/Protected field mode 2** are safety-related.
 - The CNC or safety system provides the signal. It is only absolutely necessary to connect the inputs to a safety system if communication is needed for tool detection.
 - When driven via relay contacts it is the user's responsibility to apply an appropriate safety concept.

The inputs for protected field mode 1 and protected field mode 2 can be switched directly via the 24 VDC supply. In this case, both inputs should be linked. Only the following protected field modes are possible:

- "Standard" protected field mode (switch open, both inputs = "0")
- "Box bending with back gauge" protected field mode (switch closed, both inputs = "1")

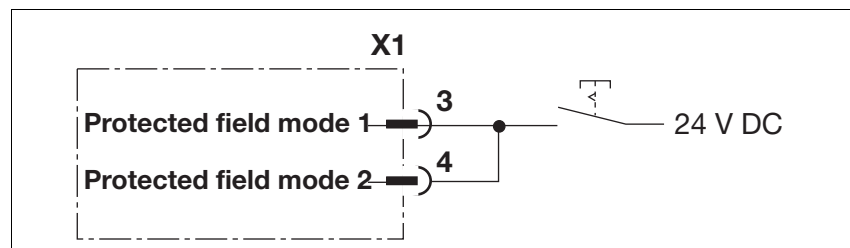

Fig. 6-1: Protected field mode 1/2 directly at the 24 V DC supply

- ▶ The input to acknowledge the specified protected field mode can be switched directly via the 24 VDC supply.



NOTICE

The acknowledgement button for the protected field mode must be positioned outside the danger zone in such a way that the operator can see all of the danger zone.

6.1 Notes on wiring

Function test

- ▶ When the wiring is complete the protective equipment will need to undergo a function test.



INFORMATION

To perform the function test, follow the procedure described in Chapter 7, "Commissioning", section entitled "Function test of the safety device".

6.2 Connections

6.2.1 Receiver

The top of the receiver has two 8-pin M12 connectors.

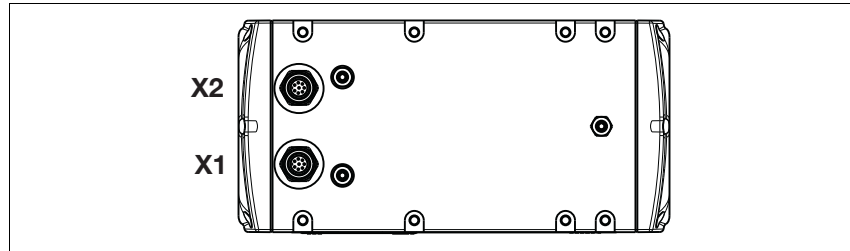

Fig. 6-2: M12 connector on the receiver

The receiver is connected via two 8-pin cables.

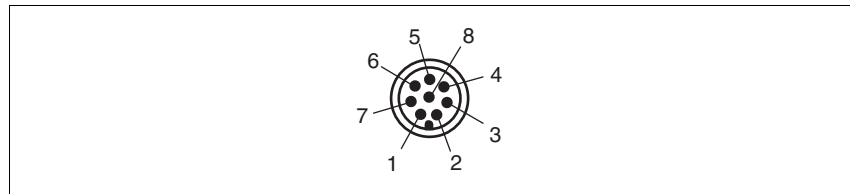

Fig. 6-3: Receiver's pin assignment

The cable ends of the Pilz ready-made cable are colour-coded. Please refer to the tables below for the coding details.

Pin assignment of M12 connector X1 on the receiver

Pin No.	Designation	Description	Colour
1	Activate *)	Output: Start communication with safety system	White
2	24 VDC	Input, 24 VDC supply voltage	Brown
3	Protected field mode 1	Input, setting of protected field modes	Green
	Tool class PLC -> PSEnvip Bit 1 *)	Input, safety system reflects tool class Bit 1	
4	Protected field mode 2	Input, setting of protected field modes	Yellow
	Tool class PLC -> PSEnvip Bit 2 *)	Input, safety system reflects tool class Bit 2	
5	OSSD1	Output, OSSD1	Grey
6	Mute1	Output, dynamic muting	Pink
	Tool class PSEnvip -> PLC Bit 1 *)	Output, sends tool class Bit 1 to safety system	
7	0 V	Input, 0 V supply voltage	Blue

6.2 Connections

Pin No.	Designation	Description	Colour
8	TRM_ON	Output, signal to switch the transmitter's light source on and off	Red
Shield	Cable shield		

*) Used in communication between PSEnvip and safety system.

Pin assignment of M12 connector X2 on the receiver

Pin No.	Designation	Description	Colour
1	Acknowledge PSEnvip -> PLC *)	Output, confirm validity of tool class	White
2	Power Off	Input, activates setup mode	Brown
	PLC Ready *)	Input, safety system signals that it is ready for communication	
3	Acknowledgement	Input, acknowledges initiation of a press stroke with reduced protected field	Green
4	System-Init	Input, the press is at top dead centre	Yellow
5	OSSD2	Output, OSSD2	Grey
6	Mute2	Output, dynamic muting	Pink
	Tool class PSEnvip -> PLC Bit 2 *)	Output, sends tool class Bit 2 to safety system	
7	0 V	Input, 0 V supply voltage	Blue
8	TRM_SYNC	Output, signal to control the intensity of the transmitter's light source	Red
Shield	Cable shield		

*) Used in communication between PSEnvip and safety system.

The two safety outputs OSSD1 and OSSD2 must be connected separately to the machine's programmable safety system. OSSD1 and OSSD2 must not be connected.

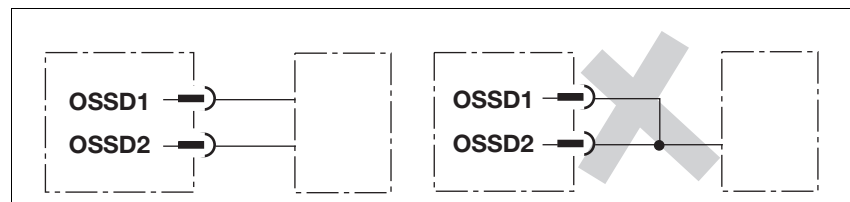

Fig. 6-4: Correct and incorrect connection of OSSD1 and OSSD2

6.2 Connections

6.2.2 Transmitter

The top of the transmitter has a 4-pin M12 connector.

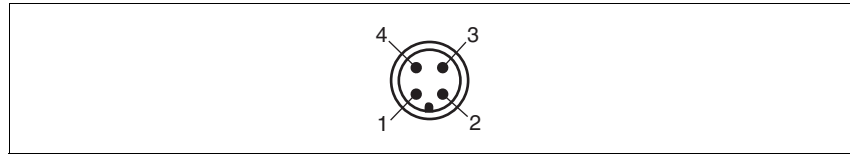

Fig. 6-5: Pin assignment of transmitter

The transmitter is connected via a 4-core cable. The cable ends of the Pilz ready-made cable are colour-coded. Please refer to the table below for the coding details.

Pin assignment of M12 connector X3 on the transmitter

Pin no.	Designation	Description	Colour
1	24 V DC	Input, 24 V DC supply voltage	brown
2	TRM_SYNC	Input, signal to control the intensity of the light source	white
3	0 V	Input, 0 V supply voltage	blue
4	TRM_ON	Input, signal to switch the light source on and off	Black
Shield	Cable shielding		

6.2.3 Supply voltage

The supply voltage is fed to the receiver and transmitter via the 8-core / 4-core connection cable.

6.2.4 Connection between transmitter and receiver

The signals TRM_ON and TRM_SYNC are routed via the control cabinet.

6.2 Connections

6.2.5 Connection diagram

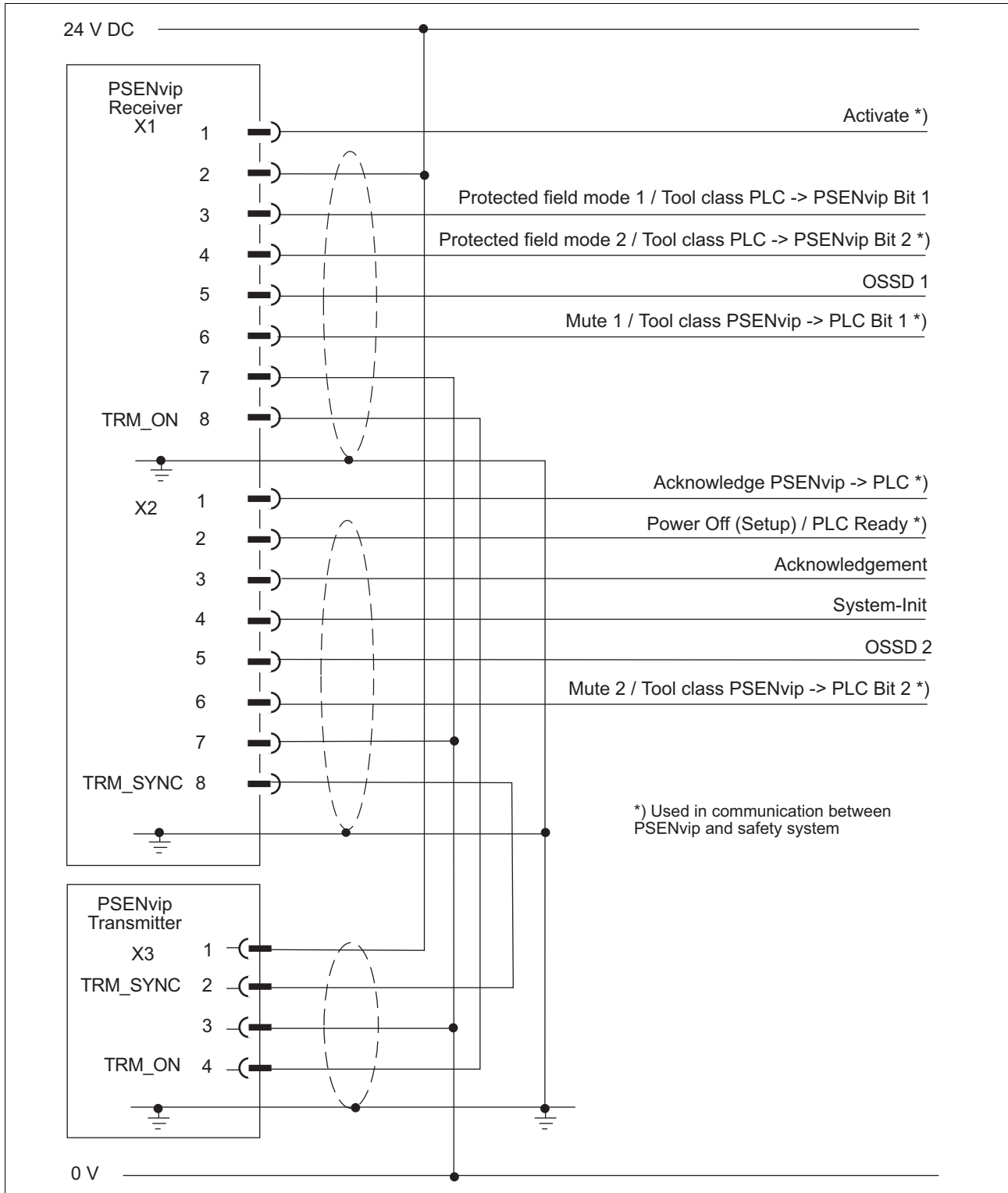
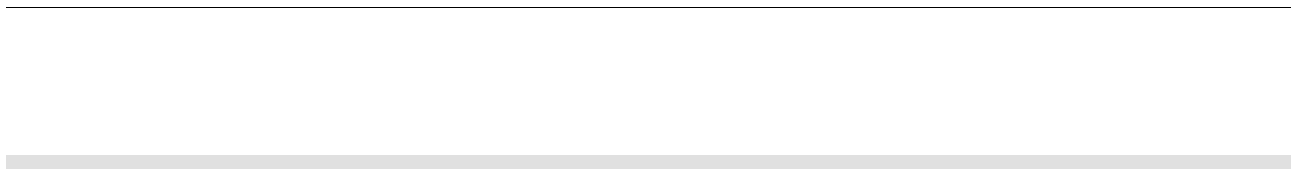

Fig. 6-6: Connection diagram



7.1 Commissioning guidelines

When commissioning for the first time, please note the following:



CAUTION!

Have the protective equipment tested and approved before commissioning for the first time!

Any machine safeguarded by the PSEnvip must be tested and approved by qualified personnel before it is placed on the market. A test report must be generated and archived during initial commissioning.

Please refer to the guidelines given in the chapter entitled "Safety", under "Qualified Personnel".

Initial commissioning involves

- ▶ Aligning the transmitter and receiver
- ▶ Tracking the adjustment line to the tip of the upper tool
- ▶ Entering the overrun
- ▶ Performing the function test using the test piece

The tool change adjustment involves

- ▶ Tracking the adjustment line to the tip of the upper tool
- ▶ Performing the function test using the test piece



NOTICE

The tool change adjustment must also be made during initial commissioning.

7.2 Initial commissioning

7.2.1 Align transmitter and receiver

Please note the following when aligning the transmitter and receiver:

- ▶ Once installed, the transmitter and receiver must be exactly aligned to each other and to the tip of the upper tool. The vertical and horizontal alignment is performed using adjustment templates and is displayed on the receiver.
- ▶ The transmitter and receiver must also be aligned after changing either the PSEnvip transmitter or receiver.

7.2.1.1 Prepare for alignment

Please note the following when preparing for alignment:

- ▶ Transmitter and receiver must be installed correctly on the press brake (see Chapter 5, "Installation") and electrically wired (see Chapter 6, "Wiring").
- ▶ An upper tool must be fitted to the right and left-hand edge of the press brake.
- ▶ Switch on the supply to the PSEnvip.

7.2.1.2 Adjustment templates

Two adjustment templates and the information on the display provide support when aligning the transmitter and receiver.

Please note the different cut-outs around the cross-hair on the two adjustment templates. On the left-hand adjustment template in the illustration below, the cross-hair is located within a square cutout. The different forms make it easier to secure information about the direction of movement when aligning the transmitter and receiver.

7.2 Initial commissioning

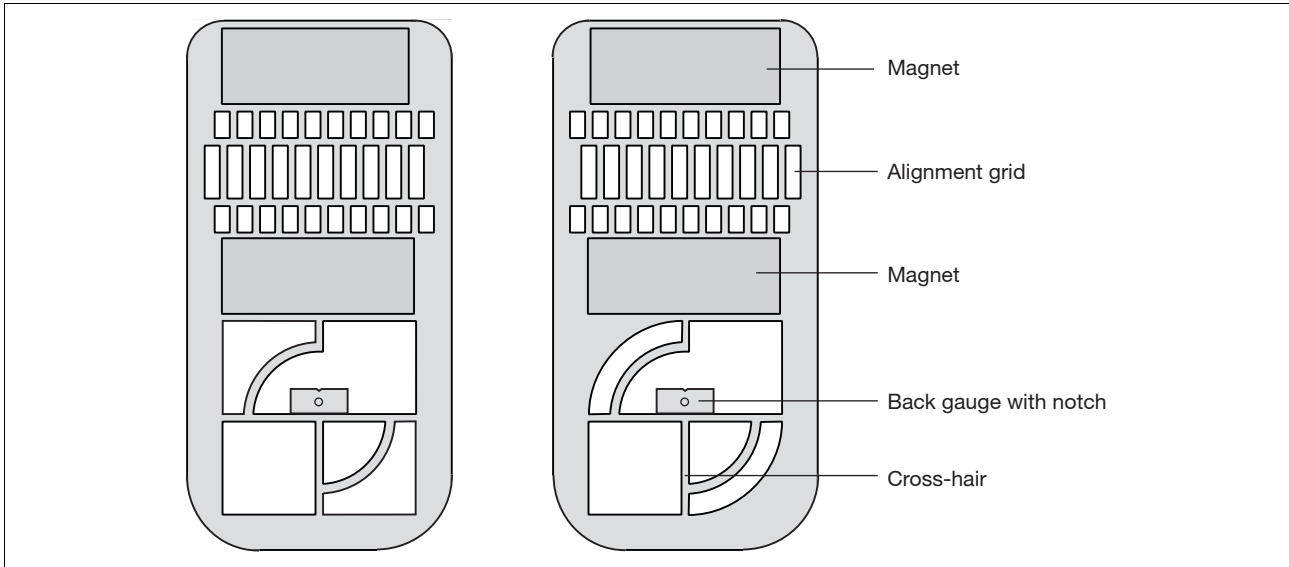

Fig. 7-1: Adjustment templates (viewed from the magnet side)

You can select either adjustment template to attach to the transmitter or receiver side.

7.2.1.3 Adjustment directions of transmitter and receiver

The PSEnvip transmitter and receiver can be adjusted in three directions.

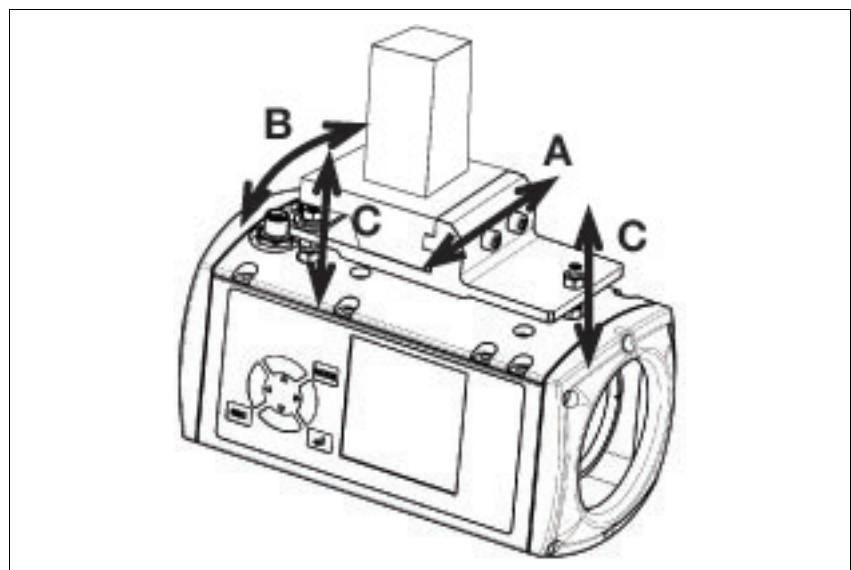

Fig. 7-2: Adjustment directions of transmitter and receiver

7.2 Initial commissioning

Direction	What?
A	Move horizontally within the groove of the adjustment plate
B	Rotate on a horizontal plane within the slot holes of the adjustment plate
C	Move vertically by adjusting the nuts on the bolts

Guidelines for the mechanical alignment of transmitter and receiver:

- ▶ When making the alignment, the nuts on the bolt connecting the PSEnvip to the adjustment plate should only be hand-tightened.
- ▶ There are three notches on the adjustment plate and auxiliary adjustment plate for rotating the transmitter and receiver. The transmitter or receiver is inserted into the slot holes on the adjustment plate (adjustment direction B).
- ▶ Push the screwdriver blade into the middle notch of the auxiliary adjustment plate and adjustment plate.
- ▶ Rotate the screwdriver blade in the required direction.
- ▶ You can use the left or right-hand notch to rotate the transmitter or receiver even further to the left or right.

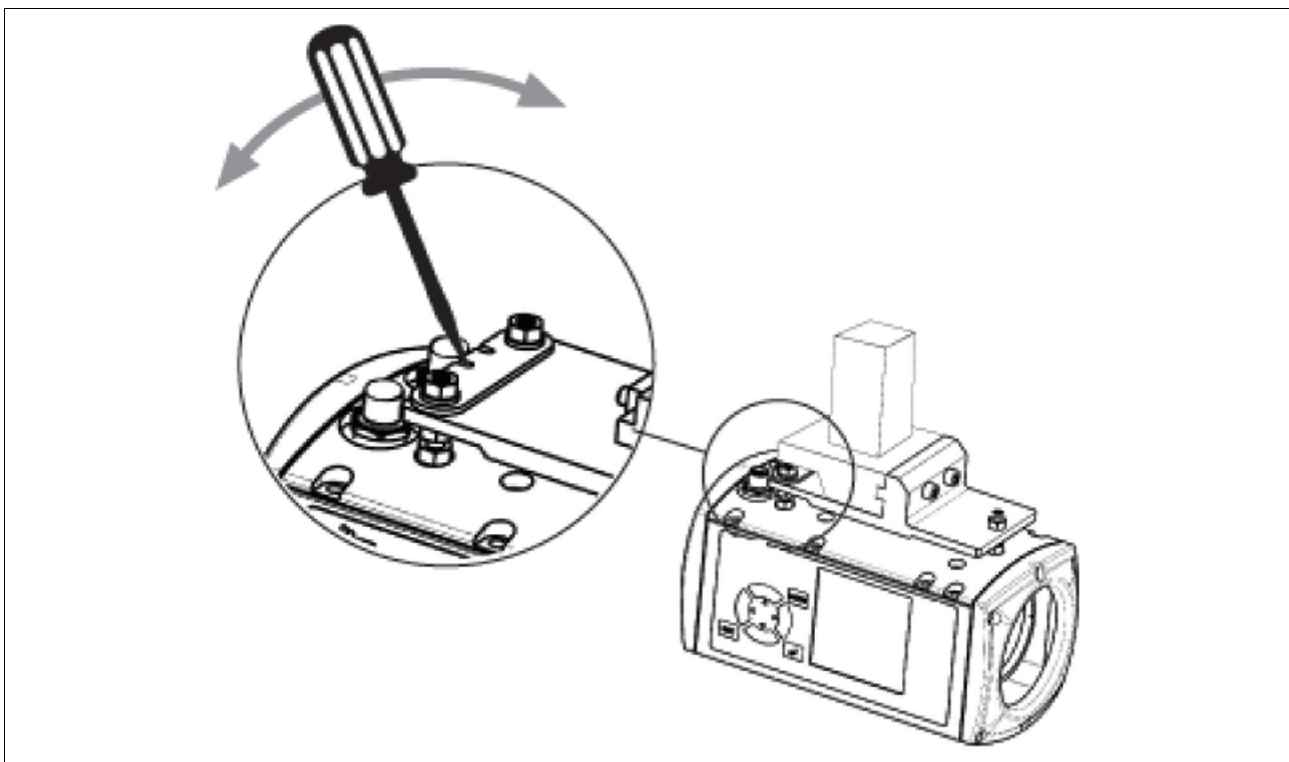

Fig. 7-3: Adjustment direction B

7.2 Initial commissioning

7.2.1.4 Align transmitter

- ▶ Attach an adjustment template with magnets to the upper tool. The tip of the upper tool must sit in the notch on the stop of the adjustment template.

Align the alignment grid of the adjustment template to the contour of the upper tool.

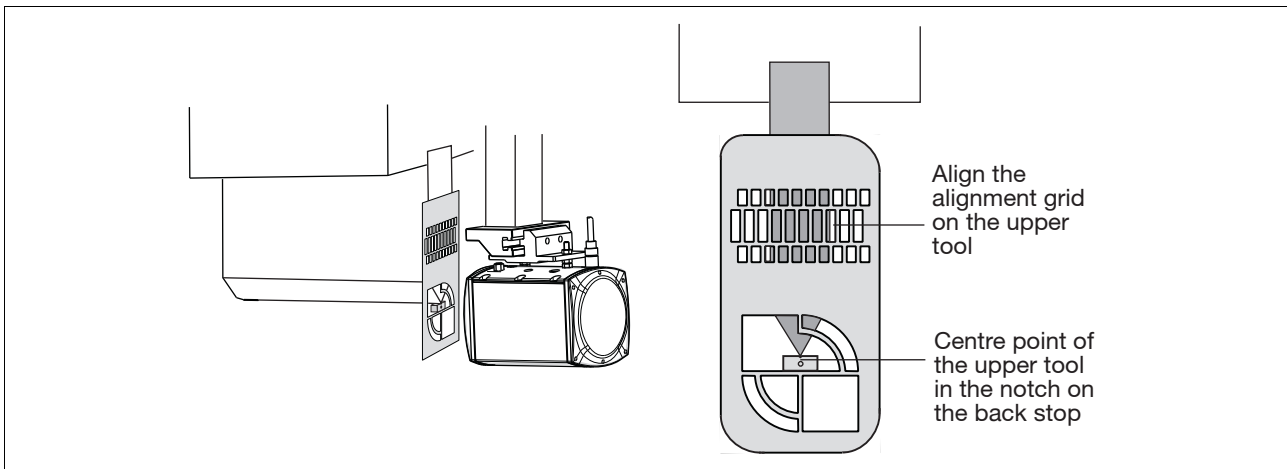

Fig. 7-4: Attach the adjustment template to the transmitter

- ▶ The illuminated target area must completely envelop the receiver. If you hold a white sheet of paper behind the receiver you will be able to see the contours of the receiver better.

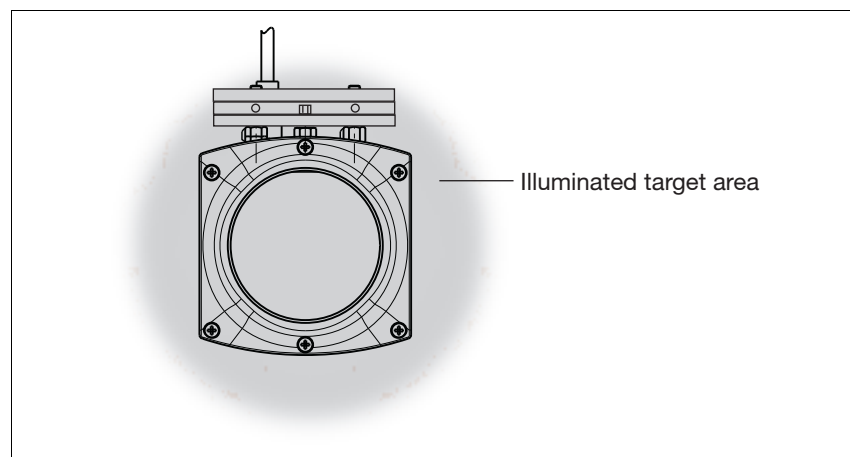

Fig. 7-5: Receiver illuminated by transmitter

- ▶ If the illuminated target area does not enclose the receiver as shown in the diagram, then you will need to realign the transmitter

7.2 Initial commissioning



INFORMATION

Carefully align the illuminated target area to the receiver. This will make the adjustments in the following work stages easier.

7.2.1.5 Tool shapes

The correct adjustment of the upper tool also depends on the tool shape. The tools are divided into tool classes in the **Tool Change** menu.



INFORMATION

You must comply with the tool class information provided in

- ▶ Section 7.3 "Adjustment during tool change", "Tool detection" in this chapter.
- ▶ Section entitled "Tool shapes", under "Safety"
- ▶ "System Connections" chapter

During initial commissioning, the upper tool should be positioned in a way that corresponds to the expected tool class.

Two bending lines are available on the PSEnvip display for correct alignment of the various tool types. In the following examples, please note that the maximum width of the respective tools for the tool class can be achieved when the appropriate bending line is used.

7.2 Initial commissioning

Examples of the correct adjustment of various tool types:

	<p>Tool class 1: Pointed tools For these tools we recommend alignment to the left-hand bending line. The distance from the bending line to the front segments of the protected field is >15 mm.</p>
	<p>Tool class 2: Semi-circular tools For these tools we recommend alignment to the left-hand bending line. The distance from the front bending line of the tool to the front segments of the protected field is <15 mm. The rear bending line of the tool is detected by the protected field. The position of the front bending line must be considered in the hazard analysis.</p>
	<p>Tool class 2: Stamp For these tools we recommend alignment to the central bending line. The distance from the front bending line of the tool to the front segments of the protected field is <15 mm. The rear bending line of the tool is detected by the protected field. The position of the front bending lines must be considered in the hazard analysis.</p>
	<p>Tool class 3: Stamp The front and rear bending lines of the tool are outside the protected field. The position of the bending lines must be considered in the hazard analysis.</p>

7.2 Initial commissioning

7.2.1.6 Align receiver

- ▶ Attach an adjustment template with magnets to the upper tool. The tip of the upper tool must sit in the notch on the stop of the adjustment template.

Align the alignment grid of the adjustment template to the contour of the upper tool.

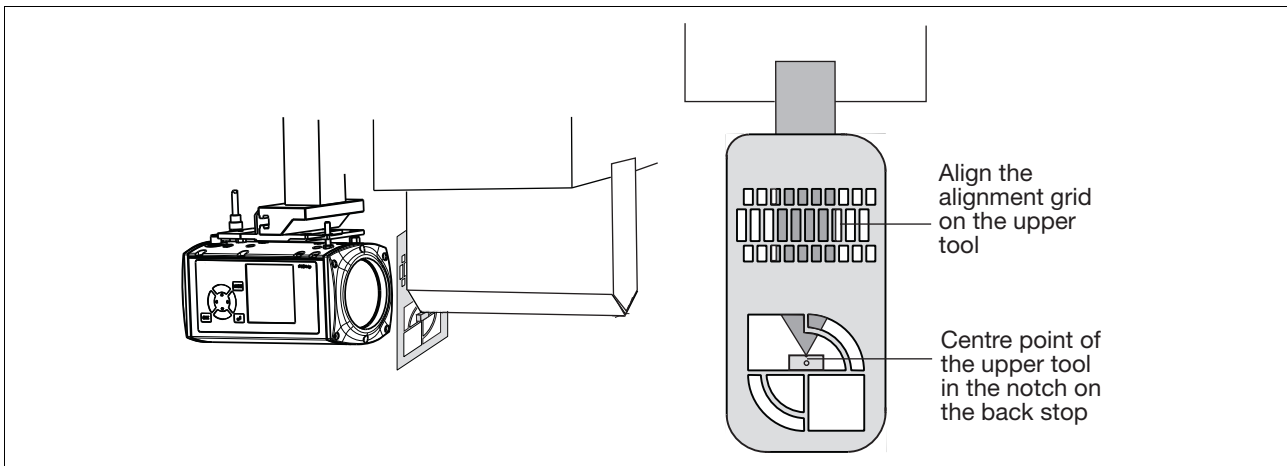

Fig. 7-6: Attach the adjustment template to the receiver

- ▶ Press the <MODE> key.
- ▶ Using the keys \blacktriangle \blacktriangledown , select the **Adjustment** option.
- ▶ Press the <ENTER> key to open the **Adjustment** option.

The adjustment image shown in the illustration below will appear on the receiver display.

Please note that the bending line is approximately 7 mm to the left of the centre of the display.

7.2 Initial commissioning

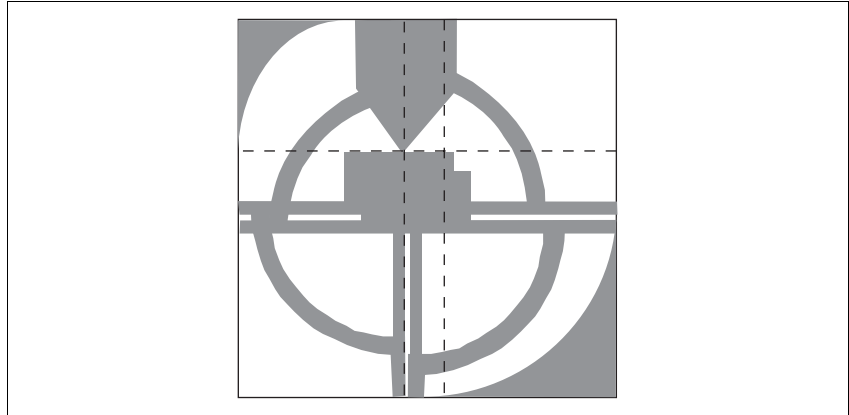

Fig. 7-7: Adjustment image

The receiver is correctly aligned with the transmitter when:

- ▶ The cross-hairs of both adjustment templates overlap
- ▶ The quadrants form a full circle and
- ▶ The centre point of the upper tool is on the bending line.

The correct adjustment image on the display will look like the image shown in the illustration below.

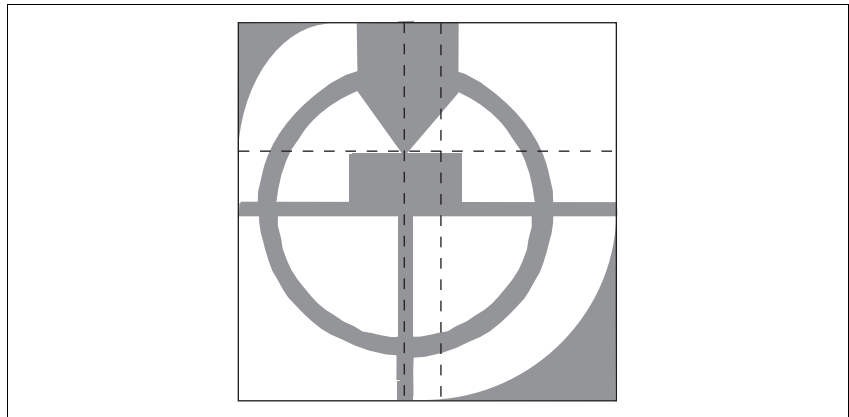

Fig. 7-8: Correct adjustment image



INFORMATION

The adjustment templates have different cut-outs around the cross-hair (see section entitled "Adjustment templates"). This makes it easier to evaluate the adjustment direction required by the transmitter and receiver.

7.2 Initial commissioning

- ▶ Adjust the direction of the receiver as described in the section entitled "Adjustment directions of transmitter and receiver".
- ▶ Remove the adjustment templates.

The correct adjustment image on the display will look like the image shown in the illustration below:

- ▶ The bending line should be on the vertical guide.
- ▶ The tool centre point should be aligned with the horizontal guide (the horizontal guide is firmly in the middle of the range bar (see section entitled "Make adjustment during tool change").

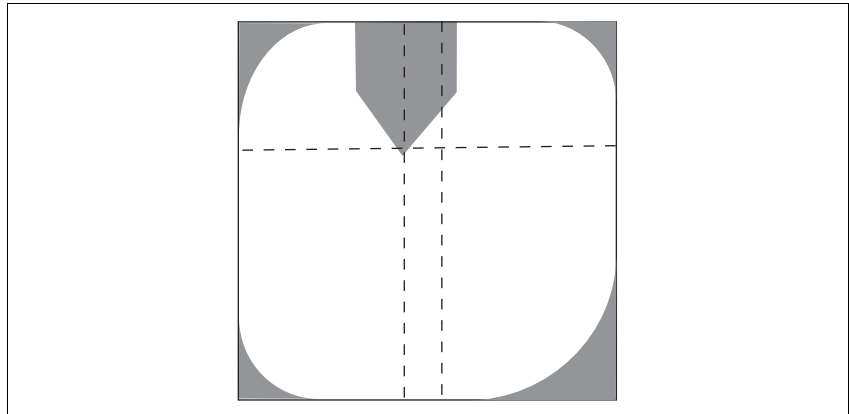

Fig. 7-9: Correct adjustment image

- ▶ Select <ENTER>.

A guide frame appears on the display. Apart from the areas around the tool centre point, the guide frame should be clear of objects. The following diagram illustrates a valid and an invalid adjustment image.

In the case of an invalid adjustment (right-hand diagram), the **Out of range** message will also appear.

7.2 Initial commissioning

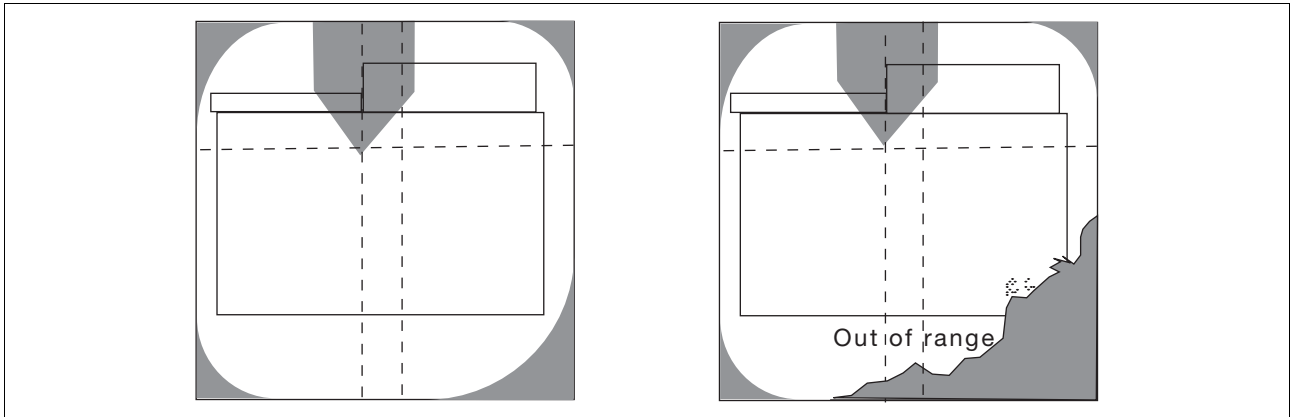

Fig. 7-10: Checking the adjustment image with superimposed guide frame

- ▶ You can switch to the adjustment image without guide frame by pressing <ENTER> again.
- ▶ Exit the adjustment using the <ESC> key.

The transmitter and receiver are now mechanically aligned.



NOTICE

After you have aligned the transmitter and receiver you will still need to carry out the step for "Adjustment during tool change" (see section entitled "Adjustment during tool change").

7.2.2 Adjustment template with bracket

An adjustment template screwed to a suitable bracket is also available as an accessory. This bracket is not supplied with the system.

- ▶ Fasten the template to the bracket using half length taper-grooved dowel pins and cylinder head bolts (see illustration).

7.2 Initial commissioning

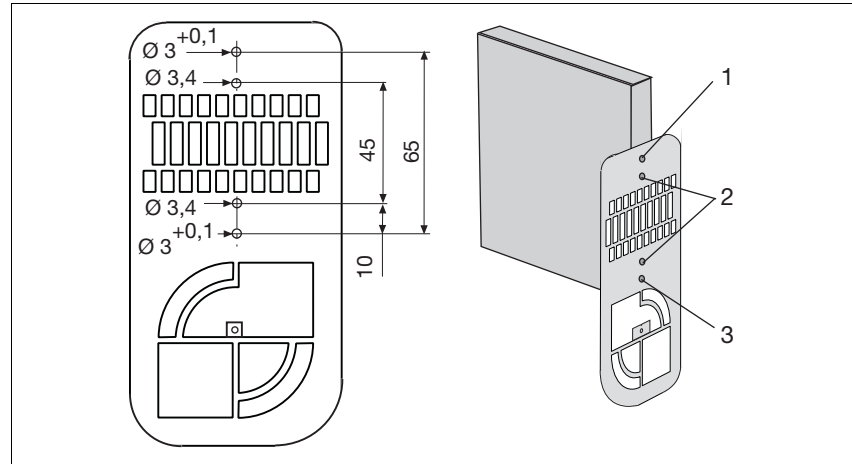

Fig. 7-11: Adjustment template to attach to bracket

- ▶ 1: Ø 3 mm DIN 1472 half length taper-grooved dowel pin
- ▶ 2: M3 x 10 cylinder head bolts
- ▶ 3: Ø 3 mm DIN 1472 half length taper-grooved dowel pin
- ▶ Attach the bracket to the upper tool clamp.

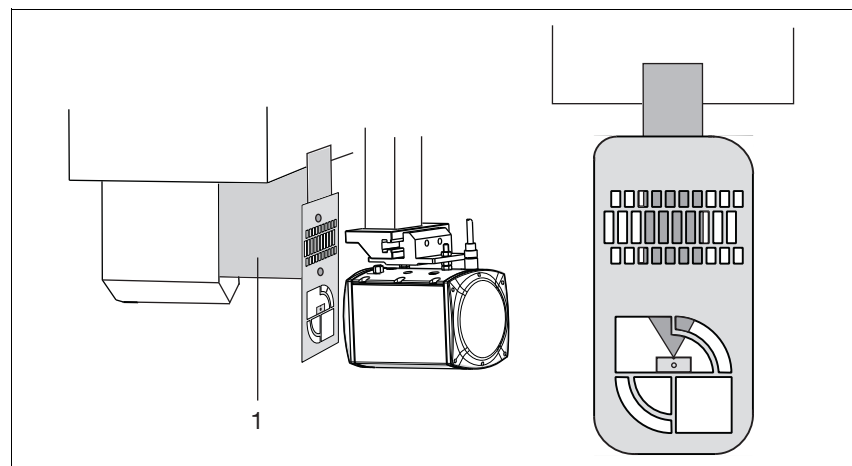

Fig. 7-12: Adjustment template with bracket

- ▶ 1: Bracket



INFORMATION

To align the transmitter and receiver, follow the same procedure as outlined in the section entitled "Align transmitter and receiver".

7.3 Adjustment during tool change

The adjustment line is automatically tracked to the tip of the tool. The tracking of the adjustment line is shown on the display.



INFORMATION

Generally you should not have to mechanically realign the transmitter and receiver during a tool change.



CAUTION!

The manufacturer or operator of the press must ensure safe selection of the "Adjustment during tool change" operating mode with appropriate measures.



CAUTION!

The protective equipment must be tested following a tool change adjustment!

Use the standardised test piece to perform a function test, see section entitled "Function test of the safety device".

7.3.1 Prepare for adjustment during tool change

- ▶ Transmitter and receiver must be exactly aligned to each other and to the centre point of the upper tool, as described in the section entitled "Initial commissioning".
- ▶ The supply voltage must be present.

7.3.2 Tool detection

All tool shapes are permitted in principle (but please refer to the warnings in the section entitled "Tool shapes", under "Safety").

In TOOL CHANGE operating mode, the PSENVip detects the contour of the tool and assigns it to a tool class.

7.3 Adjustment during tool change

Assignment to a tool class depends on

- ▶ Compliance with the requirement from EN 12622, whereby the protected field must safeguard areas lying 15 mm before the front bending line.
- ▶ Full or partial detection of the upper tool via the protected field.

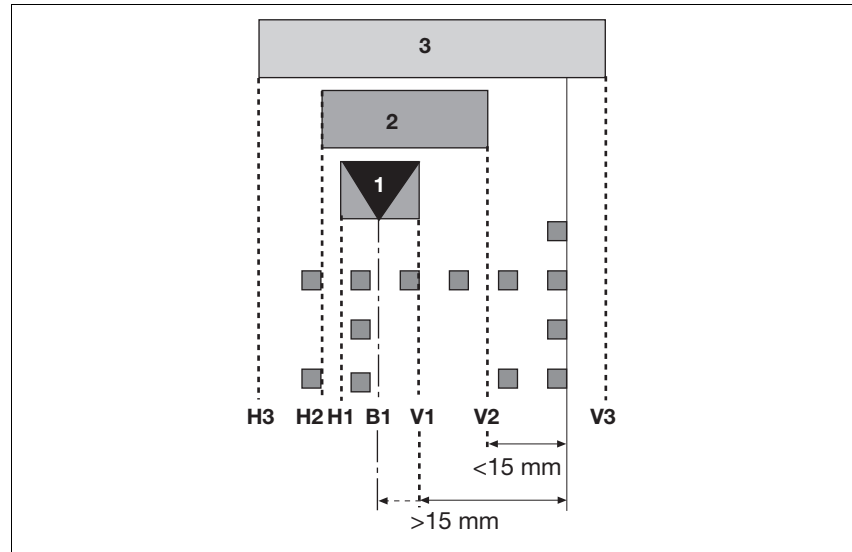

Fig. 7-13: Classification of tools into tool classes

Tool class 1

- ▶ The contour of these tools is fully detected by the PSENvip.
- ▶ The front (V1 or B1) and rear (H1 or B1) bending lines are within the protected field.
- ▶ The front segments of the protected field are at least 15 mm away from the front bending line.
- ▶ These tools are safeguarded in compliance with the standards.
- ▶ Example:

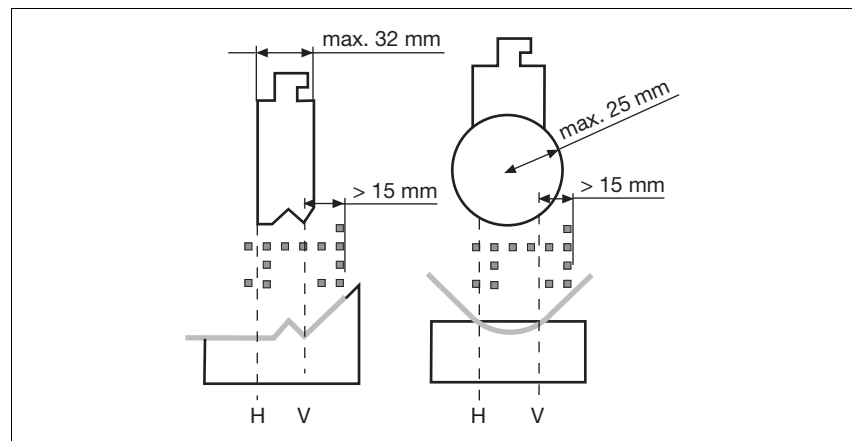

Fig. 7-14: Example for tool class 1

7.3 Adjustment during tool change

Tool class 2

- ▶ The contour of these tools is fully detected by the PSEnvip.
- ▶ The front (V2) and rear (H2) bending lines are within the protected field.
- ▶ The front segments of the protected field are less than 15 mm away from the front bending line.
- ▶ These tools are not safeguarded in compliance with the standards.
- ▶ Example:

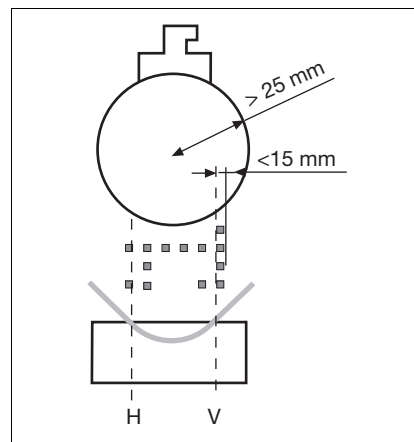

Fig. 7-15: Example for tool class 2

Tool class 3

- ▶ The contour of these tools is not fully detected by the PSEnvip.
- ▶ The front (V3) and/or rear (H3) bending lines are within the protected field.
- ▶ These tools are not safeguarded in compliance with the standards.
- ▶ Example:

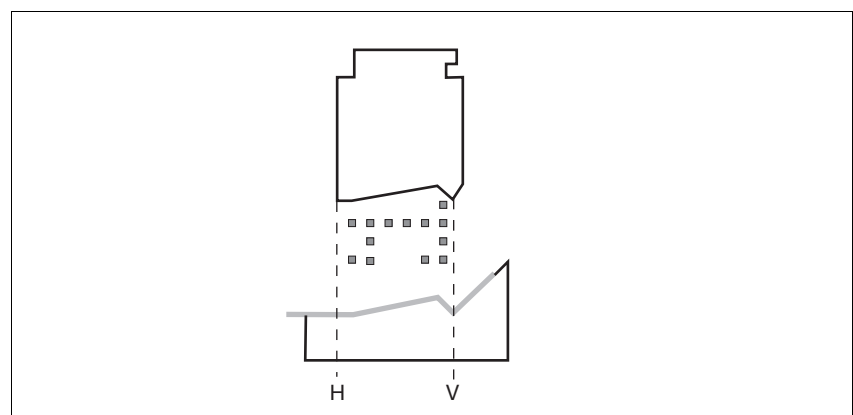

Fig. 7-16: Example for tool class 3

7.3 Adjustment during tool change

The tools are displayed as follows on the PSEnvip display:

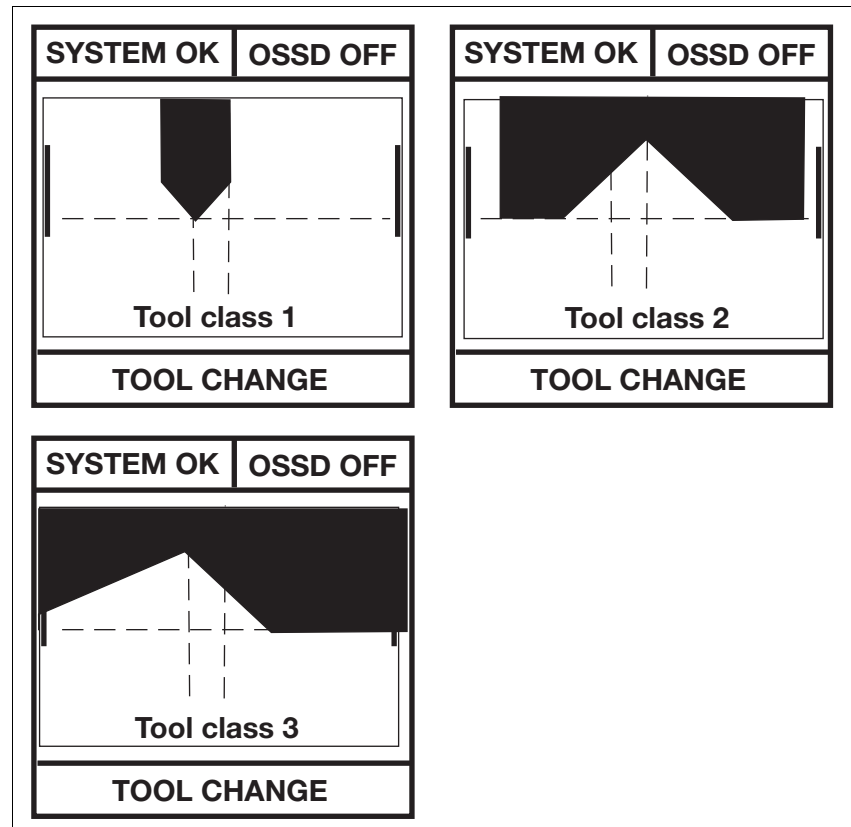



Fig. 7-17: Tool detection on the PSEnvip display

7.3.3 Make adjustment during tool change

To achieve optimum results, the tool should be aligned to an appropriate bending line during initial commissioning (see section entitled "Initial commissioning").

There are two ways of starting the function "Adjustment during tool change":

Option 1:

- ▶ Press the <MODE> key.
- ▶ Using the keys  , select the **Tool Change** option.
- ▶ Press the <ENTER> key to start the **Tool Change**.

7.3 Adjustment during tool change

Option 2:

- ▶ Press the (◀) key to start the **Tool Change**.

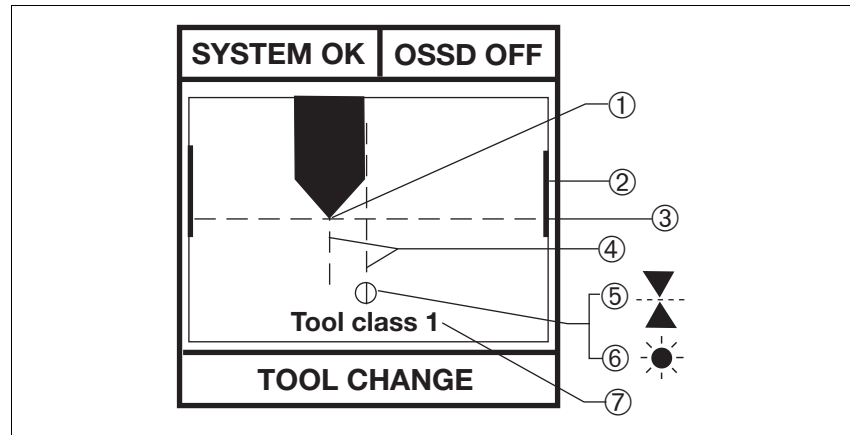

Fig. 7-18: Tool change menu

- ▶ 1: Tool centre point
- ▶ 2: Range bar
- ▶ 3: Adjustment line
- ▶ 4: Central and rear bending line
- ▶ 5: No tool identified or vertical position of tool centre point outside of the range bar
- ▶ 6: Receiver insufficiently lit by transmitter
- ▶ 7: Detected tool class

The adjustment line is automatically tracked to the tool centre point.

The vertical position of the tool centre point must be within the range bar. Once the adjustment line is at the top or bottom of the range bar,

the following symbol appears: .

If the symbol appears on the display, there is a problem with the lighting of the receiver by the transmitter:

- ▶ Check that the transmitter and receiver are aligned correctly. The illuminated target area must completely envelop the receiver. If necessary, realign the transmitter (see section entitled "Align transmitter").
- ▶ Remove any potential contamination on the lens of the transmitter or receiver.

7.3 Adjustment during tool change

The adjustment has been carried out correctly when none of the symbols appear:

- ▶ Finish the adjustment using the <ENTER> key.
The PSEnvip prompts you to confirm that you accept the new tool data:
- ▶ Within 3 seconds, press the key ◀.
- ▶ You can exit the menu at any time without confirming by pressing <ESC>. In this case, the previous tool data will be retained.

7.4 Enter overrun

The max. overrun is a press brake variable that will depend on the machine type. Once the closing movement has stopped, the max. overrun must not be exceeded.

The overrun is entered during configuration via the keypad on the PSENvip receiver.



NOTICE

The overrun may only be entered by the press brake manufacturer or suitably authorised persons.

Normally, the factory-assigned overrun is sufficient and does not have to be configured.



WARNING!

If you require a different overrun path than the factory-set path, then use the value indicated by the manufacturer on the nameplate of the press brake, or a higher value.

If you enter a lower value for the overrun, the protected field will also be reduced to an unpermitted level.

Failure to comply could result in a **hazardous situation**, which could lead to **serious injury and death**.

To enter the overrun, follow the instructions below:

- ▶ Switch off the voltage to the PSENvip.
- ▶ Press the <ESC> + <ENTER> keys and keep them held down.
- ▶ Switch the supply voltage back on.
- ▶ Release the <ESC> + <ENTER> keys when **Password?** appears on the display.
- ▶ Enter the password within 10 s.

To do this, press the following keys in the specified sequence: 1. ▲, 2. ▼, 3. ◀, 4. ▶.

The menu for entering the overrun will appear.

7.4 Enter overrun





INFORMATION

The PSEnvip will need to be restarted if the entry

- Was invalid
- Took longer than 10 s.



Fig. 7-19: Enter overrun

- ▶ Using the keys  , select the overrun that is specified on the type label of the press brake.
The permitted value range is 2 ... 14 mm, in 2 mm steps.
- ▶ Finish the entry using the <ENTER> key.
The PSEnvip prompts you to confirm that you accept the new overrun:
- ▶ Within 3 seconds, press the key .
- ▶ You can exit the menu at any time without confirming the entry by pressing <ESC>. In this case, the previous value for the overrun will be retained.



NOTICE

Once the overrun has been entered, you will have to perform a function test on the safety device (see section entitled "Function test of the safety device").

7.5 Check protective equipment

Tests are used for early identification of defects on the press brake and its safeguards. They help to maintain a safe, working condition, i.e. to prevent accidents.

The test of the protective equipment consists of:

- ▶ A function test using the test piece
and
- ▶ a visual inspection



WARNING!

The press brake must be shut down immediately if the test reveals a fault!

Failure to comply could result in a **hazardous situation**, which could lead to **serious injury and death**.

In this case, have the safety equipment checked by qualified staff.

7.5.1 Function test of the safety device

A test piece in accordance with Annex H of EN 12622 is used for the function test.

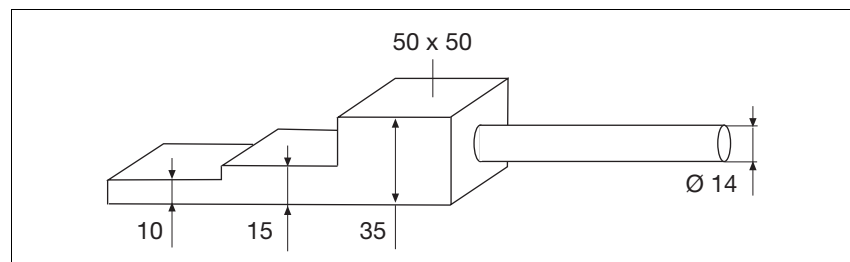

Fig. 7-20: Test piece in accordance with EN 12622

The function test on the protective equipment using the test piece involves:

- ▶ The detection of objects
- ▶ Overrun measurement

7.5 Check protective equipment

7.5.1.1 Test during initial commissioning

The machine manufacturer must perform a function test on the safeguard before putting the press brake into service. During this test the press brake must be fully configured with the upper tool (maximum weight). The test should be performed at maximum closing speed.



INFORMATION

The test during initial commissioning may only be carried out by qualified personnel.

7.5.1.2 Test after machine modification

The safeguards should be tested after each machine modification (e.g. after entering the overrun, after a tool change, after changes to the press controller). The tests should be the same as those carried out during initial commissioning.

Changing the PSEnvip or swapping PSEnvip components should also be regarded as a modification.

You must comply with the requirements of the applicable national regulations.



INFORMATION

The check following modifications may only be carried out by qualified personnel.

7.5.1.3 Regular check

Safeguards must undergo a regular function test:

- ▶ After switching on the supply voltage for the first press stroke
- ▶ At least every 30 hours



NOTICE

The safety-related control system must request these regular inspections of the safeguard via a user program.

7.5 Check protective equipment



INFORMATION

Trained operators must be used for the daily check.

Depending on the level of use, safety devices and safety measures on the press brake must be checked at least once a year by an appointed expert (competent person) to ensure they are in a safe condition. The result of these tests must be entered in the inspection book or in the machine file. Any serious non-conformances must be rectified before the press brake is returned to operation.



INFORMATION

The annual inspection may only be carried out by qualified personnel.

7.5.1.4 Prepare for function test

Proceed as follows:

- ▶ During initial commissioning the press brake is fully configured with the upper tool (maximum weight).
- ▶ Transmitter and receiver are correctly aligned (see "Initial commissioning").
- ▶ The press brake is at top dead centre.
- ▶ Transmitter and receiver are ready for operation.
- ▶ Standard protected field mode is selected.

7.5.1.5 Function test using the test piece

Function test using the test rod (= test piece handle)

- ▶ Move the test rod (14 mm diameter) slowly along the whole detection zone at the centre point of the upper tool.

7.5 Check protective equipment

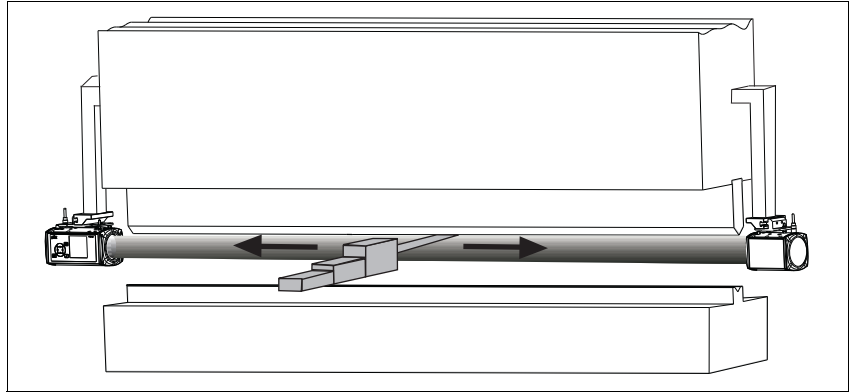

Fig. 7-21: Function test using test rod

The test rod must be detected along the whole length of the detection zone.

The OSSDs switch to the OFF state. The LED on the receiver lights up red.



INFORMATION

The following tests must be run on the left- and right-hand end as well as in the centre of the press brake:

- During initial commissioning: 10 times
- During the daily check and during a tool change: 3 times

Function test with 10 mm and 15 mm test piece

- ▶ Position the 10 mm high section of the test piece on top of the lower tool.
- ▶ Initiate a press stroke.

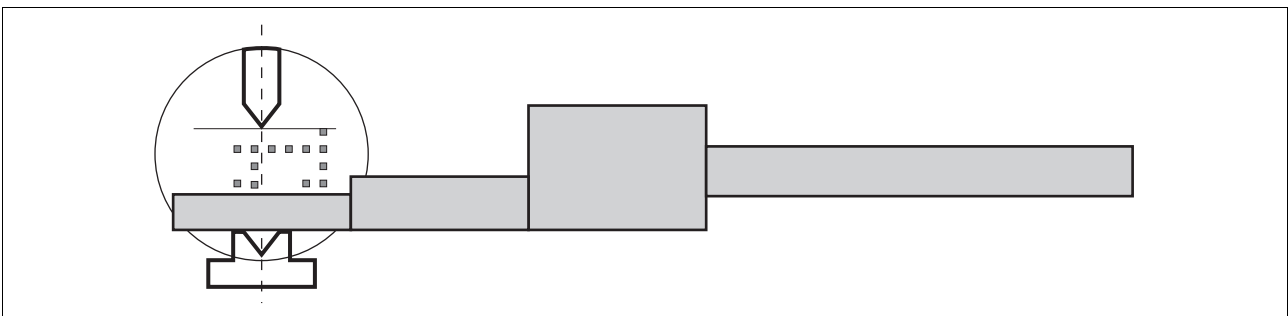

Fig. 7-22: Function test using test piece

7.5 Check protective equipment

The test piece interrupts the advance measuring field. The press stroke is stopped. The upper tool should not touch the test piece.

- ▶ Once the press stroke has stopped, push the 15 mm high section of the test piece beneath the upper tool.

The upper tool should not touch the test piece.

Function test using the 35 mm test piece

- ▶ Start up the press.
- ▶ Position the 35 mm high section of the test piece on top of the lower tool.
- ▶ Initiate a press stroke.

The test piece interrupts the advance measuring field. The press stroke is stopped. The upper tool should not touch the test piece.

7.5.2 Visual inspection

Check the following on the PSEnvip transmitter and receiver

- ▶ The condition of the installation and attachment
 - ▶ Any damage on the housing and lens
 - ▶ Electrical connections
-
- ▶ Switch on the machine.
 - ▶ Check the messages on the display.

8.1 Safety guidelines

Please note the following safety safety guidelines during operation:

Prior to operation:

Carry out the daily checks on the protective equipment prior to operation (see Chapter 7, "Commissioning", section entitled "Function test of the safety device").

8.2 Operating notes

8.2.1 Switch on PSEnvip

The PSEnvip is ready for operation once supply voltage has been applied and the self test has been carried out.

- ▶ Switch on the supply voltage.
A self-test runs while the start screen is displayed on screen.
An error message will appear if an error is detected.



INFORMATION

Information on the error that has occurred and how to rectify it can be found in the chapter entitled "Diagnostics and Troubleshooting".

Rectify the error.

If no error has been detected, the display will show the status of the OSSD and the protected field mode that is currently selected, which is standard in the example.

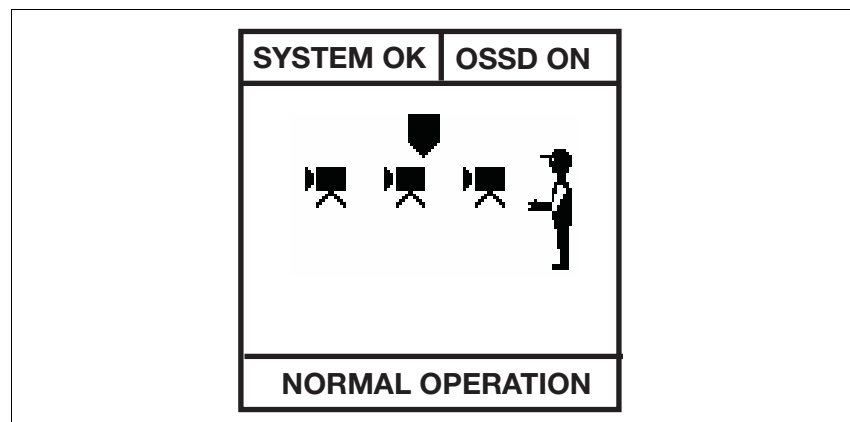

Fig. 8-1: Display after power-up

8.2.2 Muting lamp

Muting lamps warn of residual hazards associated with the safeguard.

8.2.3 Initial press stroke

When the initial press stroke occurs after the machine is switched on, a function test must be carried out on the PSEnvip, using the test piece.





- ▶ Set standard protected field mode.

8.2 Operating notes

- ▶ Operate the foot switch to initiate the press stroke.
- ▶ Use the test piece to carry out the function test (see Chapter 7, "Function test of the safety device").

8.2.4 Acknowledge protected field modes

The protected field modes are shown on the display as follows:

Standard	Box bending	Back gauge	Box bending with back gauge
			



INFORMATION

The display of the available protected field modes also depends on the selected tool class. Please refer also to the section entitled "Protected field modes", under "Function Description".



WARNING!

Crushing and trapping of fingers or hands!

With box bending protected field mode, the front segments of the protected field are blanked.

Around the bending line there is an increased risk of crushing and trapping of fingers or hands.

Make sure that the workpiece is handled correctly (see Chapter 3, "Safety").



WARNING!

Crushing and trapping of fingers or hands!

With box bending with back gauge protected field mode, both the front and rear segments of the protected fields are blanked.

Around the bending line there is an increased risk of crushing and trapping of fingers or hands.

Make sure that the workpiece is handled correctly (see Chapter 3, "Safety").

8.2 Operating notes

An acknowledgement button must be operated to initiate a press stroke with a reduced protected field.

When initiating a press stroke while the protected field is reduced (box bending with or without back gauge), please note the following:

Until the acknowledgement button is pressed, the display of the protected field to be blanked changes.

- ▶ Insert the workpiece.
- ▶ Press the acknowledgement button and release it again.
- ▶ Operate the foot switch to initiate the press stroke.

The press brake initiates the press stroke with reduced protected field.

8.2.5 Tool change

After a tool change, proceed as follows:

- ▶ Track the adjustment line to the tool centre point. See Chapter 7, "Commissioning", section entitled "Adjustment during tool change".
- ▶ Carry out a function test using the test piece. See Chapter 7, "Commissioning", section entitled "Function test of the safety device".



INFORMATION

Generally you should not have to mechanically realign the transmitter and receiver after a tool change. However, if this should be necessary, follow the instructions given in Chapter 7, "Commissioning", section entitled "Initial commissioning".

8.2.6 Error messages

Internal and external errors are displayed on the receiver.



INFORMATION

Details of the error messages and corresponding remedies are given in Chapter 9, "Diagnostics and Troubleshooting".

8.2 Operating notes

8.2.7 Cleaning the front lenses

The front lenses on the transmitter and receiver should be cleaned at regular intervals, using an alcohol glass cleaner.



NOTICE

Never use aggressive solvents or abrasive cleaning agents!

- ▶ Remove the dust from the front lens using a soft brush.
- ▶ Spray the front lens using an alcohol glass cleaner. Do not allow drops to form on the lens.
- ▶ Use a soft cloth to wipe across the whole of the front lens.
- ▶ Remove any heavier dirt without scratching the front lens.
- ▶ Carry out a function test using the test piece. See Chapter 7, "Commissioning", section entitled "Function test of the safety device".

Please note the following safety guidelines when errors occur:



WARNING!

The press brake must be shut down immediately if the test reveals a fault!

Failure to comply could result in a **hazardous situation**, which could lead to **serious injury and death**.

In this case, have the safety equipment checked by qualified staff.

9.1 Error Management

The PSEnvip continuously carries out self-tests and output tests during operation. If an error is discovered, the following sequence is triggered:

- ▶ An error identifier is shown on the display of the PSEnvip receiver (see "Error messages" in this chapter)
- ▶ The error plus some additional diagnostic data is entered in a special data area on the PSEnvip (see "DIAGNOSTICS menu" in this chapter)
- ▶ Execution of the error reaction.

The PSEnvip's reaction to an error depends on the severity of that error.

9.1.1 Minor errors

Possible causes

- ▶ Feasibility error
- ▶ Internal error

Reaction of the PSEnvip

- ▶ The PSEnvip switches to a HOLD state.
- ▶ Outputs **OSSD1/OSSD2** on the receiver are switched off.
- ▶ In this state it is possible to make adjustments during initial commissioning and after a tool change.

Remedy

- ▶ Note the error message (see section entitled "Error messages").
- ▶ Rectify the error.
- ▶ Press the <ESC> key and return the PSEnvip to the NORMAL OPERATION state.

9.1.2 Major errors

Possible causes

- ▶ Serious internal error
- ▶ Wiring error, short across contacts, short circuit
- ▶ No valid tool data
- ▶ Overrun not entered
- ▶ Fault on the optical system

Reaction of the PSEnvip

- ▶ The PSEnvip switches to a STOP state.
- ▶ Outputs **OSSD1/OSSD2** on the receiver are switched off.
- ▶ In this state, operation is no longer possible. However, diagnostics are available.

9.1 Error Management

Remedy

- ▶ Note the error message (see section entitled "Error messages").
- ▶ Rectify the error.
- ▶ Restart the PSEnvip: Switch supply voltage off and then on again.

9.1.3 Fatal errors

Possible causes

- ▶ Major system defect
- ▶ Error during self-test

Reaction of the PSEnvip

- ▶ The PSEnvip switches to a FATAL state. It remains in a safe condition.
- ▶ Outputs **OSSD1/OSSD2** on the receiver are switched off.
- ▶ The transmitter's light source goes out.
- ▶ In this state, operation is no longer possible. The display is no longer operable. Diagnostics are no longer available.

Remedy

- ▶ It is not possible for the user to rectify the error.
- ▶ Note the conditions under which the error occurred.
- ▶ Restart the PSEnvip: Switch supply voltage off and then on again.
- ▶ The error message will not be displayed. However, it will be possible to select the **DIAGNOSTICS** menu.
- ▶ Note the error message (see section entitled "Error messages").
- ▶ Contact Pilz.

9.2 Error messages

Error messages appear on the display as soon as an error occurs.

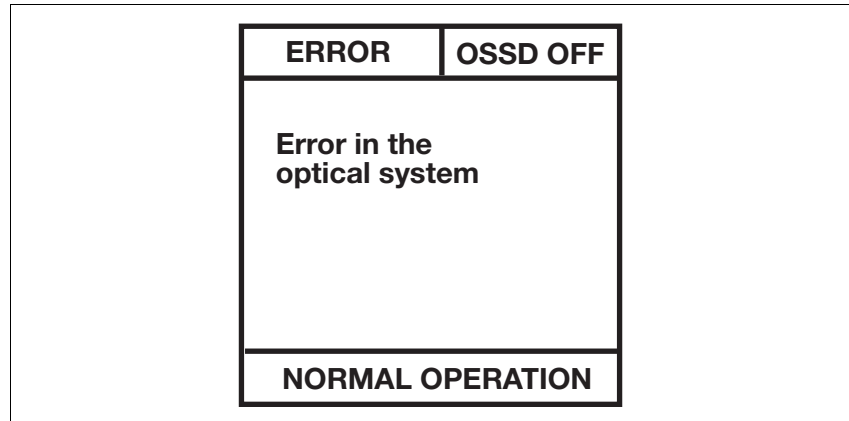

Fig. 9-1: Error messages on the display

Error message on the display	Error message	Remedy
<p>Not relevant to the user</p> <p>Press ESC to proceed</p>	<p>Not relevant to the user</p> <p>Press ESC to continue</p>	<p>1.) Acknowledge the error by pressing ESC</p>
<p>Internal error</p> <p>STOP</p>	<p>Internal error</p> <p>STOP</p>	<p>1.) Restart the PSEnvip: Switch supply voltage off and then on again</p> <p>2.) Change the receiver</p>
<p>Wiring error</p>	<p>Wiring error</p>	<p>1.) Restart the PSEnvip: Switch supply voltage off and then on again</p> <p>2.) Ensure that the wiring is correct</p> <p>3.) Rectify short circuit between the inputs and/or outputs and 0 V / 24 V</p> <p>4) Change the receiver</p>
<p>Initial commissioning</p>	<p>Initial commissioning</p>	<p>1.) Please contact Pilz</p>
<p>No valid data detected (tool and/or overrun)</p>	<p>No valid data detected (tool and/or overrun)</p>	<p>1.) Enter overrun and/or make adjustment during tool change</p>
<p>No adjustment performed after tool change</p>	<p>No adjustment performed after tool change</p>	<p>1.) Make adjustment during tool change</p>

9.2 Error messages

Error message on the display	Error message	Remedy
Error in the optical system	Error in the optical system	1.) Acknowledge the error by pressing ESC 2.) Restart the PSEnvip: Switch supply voltage off and then on again 3.) Clean the front lenses on the transmitter and receiver 4.) If necessary, eliminate the external light source 5.) Mechanically realign the transmitter and receiver (as described under "Initial commissioning") 6.) Change receiver and/or transmitter
Tool size exceeded or Communication error with safety system	Tool size exceeded or Communication error with safety system	1.) Use smaller tool or 1.) Acknowledge the error by pressing ESC 2.) Check the user program; it must support communication for wide tools and ensure the correct assignment of inputs and outputs 3.) Check the wiring
Incorrect tool data Repeat tool change adjustment	Incorrect tool data Repeat tool change adjustment	1.) Clean the front lenses on the transmitter and receiver 2.) Remove any dirt on the tool



INFORMATION

Please contact Pilz if none of the suggested remedies are able to rectify the error.

9.3 DIAGNOSTICS menu

The **DIAGNOSTICS** menu provides Pilz service staff with further information to help them identify faults.

- ▶ Press the <MODE> key.
- ▶ Using the keys \blacktriangle \blacktriangledown , select the **DIAGNOSTICS** menu.
- ▶ Press the <ENTER> key to open the **DIAGNOSTICS** menu.

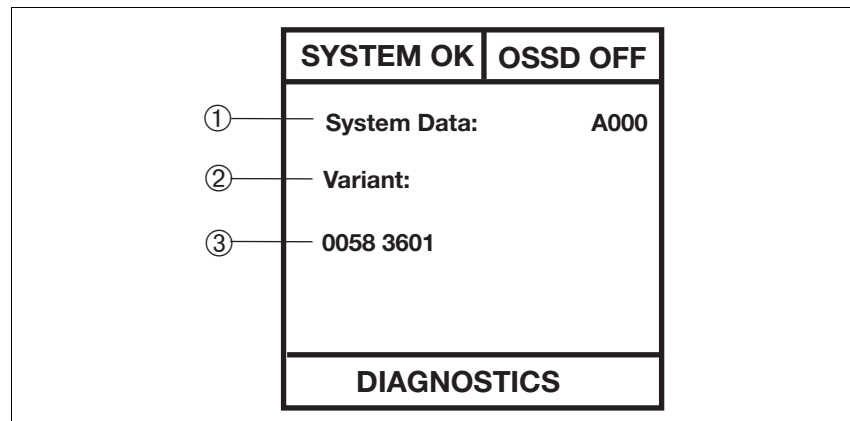

Fig. 9-2: Diagnostic data on the display

- ▶ 1: Diagnostic block
- ▶ 2: Diagnostic data
- ▶ 3: Data in hex

9.3.1 Diagnostic blocks and diagnostic data

The **System Data** diagnostic block contains the following diagnostic data:

- ▶ Type: The type of PSEnvip
- ▶ SW Version: The software version of PSEnvip
- ▶ Device Data: Device data
- ▶ Configuration: Overrun
- ▶ Tool Data: Tool data
- ▶ Error Statistic: Information on the error rate
- ▶ Thresholds: Information on the optical system
- ▶ Mod Limits: Information on the optical system
- ▶ Run Statistic: Information on the optical system
- ▶ Adjust Statistic: Information on the optical system

9.3 DIAGNOSTICS menu



The Error Data diagnostic block contains the following diagnostic data:

- ▶ Error stack with the last 10 entries

The Log Data diagnostic block contains the following diagnostic data:

- ▶ Log data: Log book data.

- ▶ Press the <MODE> button to access the next diagnostic block.

- ▶ Press the   keys to access the diagnostic data within a diagnostic block.

- ▶ Exit the **DIAGNOSTICS** menu using the <ESC> key.

10.1 Requirements of the user program

The automation system PSS 4000 from Pilz is required to run PSEnvip. In the PSS 4000 user program the following safety functions must be implemented to safeguard the dynamic muting of PSEnvip:

- ▶ Monitoring of the pinch point
 - Calculating an expectation for switching off the outputs Mute 1/2, based on the process data of CNC (pinch point) The pinch point must be safety-related in the user program to do this.
 - Press stop when switching off of the outputs Mute 1/2 of PSEnvip does not correspond to the expectation. This is the case, for example, when an obstacle (e.g. a hand) rests on the plate and the outputs Mute 1/2 are switched off earlier than expected.
 - The monitoring of the pinch point must be performed in each press stroke.
- ▶ Monitoring of the braking ramp

PSEnvip reduces its protected field during dynamic muting. The monitoring of the press brake ramp must ensure that also the reduced protected field can at any time stop the movements of the upper tool in time. This is only possible when the press speed is reduced accordingly.

If for example the brake ramp is launched too late, the PSS 4000 stops the press.
- ▶ Determining of a safe position and a safe speed of the upper tool

Safe evaluation of the encoders (e.g. incremental encoders) is the prerequisite for monitoring the pinch point and the press brake ramp.

For the safety functions described Pilz offers a certified evaluation program for the PSS 4000.

In chapter 4.7 "System cycle" the signal behaviour of the outputs OSSD and Mute are described in detail.

10.2 Communication with the safety system

For communication between PSEnvip and the safety system, please note the following information in this manual:

- ▶ Information on the inputs and outputs used for communication and information on the communication sequence: Section entitled "Communication with the safety system", under "Function Description"
- ▶ Safety guidelines on tool shapes, under "Safety"
- ▶ Information on tool detection, in the section entitled "Adjustment during tool change", under "Commissioning"

The user program in the safety system must support communication with the PSEnvip, if tools of tool class 2 or 3 are used. The user program does not need to support this communication if tools of tool class 1 are used exclusively.

Communication only occurs in the system status TEST. This status is adopted

- ▶ After power-up.
- ▶ After a tool change.
- ▶ After a 0/1 pulse edge at the input System-Init.
- ▶ Periodically every 2 minutes.

The PSEnvip starts communication via a 0/1 pulse edge at the Activate output (X1, 6).

The various tool classes have the following requirements of the user program:

Tool class 1

- ▶ The user program confirms tool class 1. The PSEnvip switches to a RUN state.
- ▶ The PSEnvip switches to a HOLD state if
 - The tool class sent by the PSEnvip and reflected by the user program do not match.
 - Errors occur in the communication protocol.
 - Overall communication takes longer than 600 ms.
 - A single communication phase takes longer than 200 ms (see Chapter 4-4, section entitled "Communication sequence").
- ▶ Note:

The PSEnvip switches to a RUN state if the user program fails to react to the communication request via the PSEnvip once a timeout of 200 ms has elapsed.

As a result, tools of tool class 1 can also be used with user programs that do not support communication.

10.2 Communication with the safety system

Tool class 2

- ▶ The user program confirms tool class 2. The PSEnvip switches to a RUN state.
- ▶ The PSEnvip switches to a HOLD state if
 - No communication is established (within 30 s on power-up, otherwise within 200 ms).
 - The tool class sent by the PSEnvip and reflected by the user program do not match.
 - Errors occur in the communications protocol.
 - Overall communication takes longer than 600 ms.
 - A single communication phase takes longer than 200 ms (see Chapter 4-4, section entitled "Communication sequence").
- ▶ The switchover point must be raised in comparison with the regular switchover point. The switchover to lower speed must take place earlier.
- ▶ The user program must convey a higher switchover point to the CNC controller and then monitor this.

Tool class 3

- ▶ The user program confirms tool class 3. The PSEnvip switches to a RUN state.
- ▶ The PSEnvip switches to a HOLD state if
 - No communication is established (within 30 s on power-up, otherwise within 200 ms).
 - The tool class sent by the PSEnvip and reflected by the user program do not match.
 - Errors occur in the communications protocol.
 - Overall communication takes longer than 600 ms.
 - A single communication phase takes longer than 200 ms (see Chapter 4-4, section entitled "Communication sequence").
- ▶ The switchover point must be raised in comparison with the switchover point for tool class 3. The switchover to lower speed must take place even earlier.
- ▶ The user program must convey a higher switchover point to the CNC controller and then monitor this.
- ▶ If the press is at top dead centre (TDC), each press stroke must be acknowledged before it is initiated. Only after this acknowledgement are the OSSDs switched on, enabling rapid traverse for the press.

10.2 Communication with the safety system

Program example for communication between the PSEnvip and a safety system from the automation system PSS 4000:

```

FUNCTION_BLOCK PSEnvipCom
VAR_INPUT
bStartToolChangeE0      : SAFEBOOL;      // Start signal for the communication from
                                PSEnvip
bValidToolChangeE1      : SAFEBOOL;      // Tool value from PSEnvip is valid
bToolTypeE2             : SAFEBOOL;      // Tool value Bit 0 from PSEnvip
bToolTypeE3             : SAFEBOOL;      // Tool value Bit 1 from PSEnvip
uiToolTypeCNC           : SAFEUINT;      // Tool value from the CNC
END_VAR

VAR_OUTPUT
bAcknowledgeToolChangeA0 : SAFEBOOL;      // Acknowledge signal for the communication
                                from PSS4000
bAcknowledgeToolTypeA1   : SAFEBOOL;      // Tool value Bit 0 from PSS4000
bAcknowledgeToolTypeA2   : SAFEBOOL;      // Tool value Bit 1 from PSS4000
END_VAR

VAR
RisingFlagE0             : R_TRIG;      // FUNCTION block rising edge for Signal E0
RisingFlagE1             : R_TRIG;      // FUNCTION block rising edge for Signal E1
bComEnd                  : BOOL;        // End of communication
bToolchangeFlag          : BOOL;        // Rising edge for start of the communication
bToolValidFlag           : BOOL;        // Rising edge for valid tool from PSEnvip
bStartCom                : BOOL;        // Start communication
bToolValid               : BOOL;        // Tool from PSEnvip is valid
uiToolTypePSEnvip        : SAFEUINT;    // Tool type from PSEnvip
END_VAR

// Communication between PSEnvip and PSS4000

CAL    RisingFlagE0(
    clk := bStartToolChangeE0,
    q => bToolchangeFlag
)

```

10.2 Communication with the safety system

```
LD      bToolchangeFlag
S       bStartCom

// Waiting for the communication start
LDN     bStartCom
ORN     bStartToolChangeE0
JMPC   RESTORE

// Acknowledge for the communication from PSS4000 to PSEnvip
LD      TRUE
ST      bAcknowledgeToolChangeA0

CAL     RisingFlagE1(
clk := bValidToolChangeE1,
q => bToolValidFlag
)

LD      bToolValidFlag
S       bToolValid

// Waiting for the tool valid signal from PSEnvip
LDN     bToolValid
JMPC   END

// Tool NOT Valid
ANDN    bToolTypeE2
ANDN    bToolTypeE3
JMPC   END

// Tool class 01
LDN     bToolTypeE2
AND     bToolTypeE3
JMPC   TOOL01

// Tool class 02
LD      bToolTypeE2
ANDN    bToolTypeE3
JMPC   TOOL02
```

10.2 Communication with the safety system

```
// Tool class 03
LD     TRUE
ST     bAcknowledgeToolTypeA1
ST     bAcknowledgeToolTypeA2
LD     UINT#3
ST     uiToolTypePSEnvip
JMP    ENDDATATRANSFER

TOOL01:

LD     TRUE
STN    bAcknowledgeToolTypeA1
ST     bAcknowledgeToolTypeA2
LD     UINT#1
ST     uiToolTypePSEnvip
JMP    ENDDATATRANSFER

TOOL02:

LD     TRUE
ST     bAcknowledgeToolTypeA1
STN    bAcknowledgeToolTypeA2
LD     UINT#2
ST     uiToolTypePSEnvip

ENDDATATRANSFER:

// Comparing the tool value between PSEnvip and CNC
LD     uiToolTypePSEnvip
NE     uiToolTypeCNC
JMP    END

// Waiting for the end of communication
LD     bStartToolChangeE0
OR     bValidToolChangeE1
OR     bToolTypeE2
OR     bToolTypeE3
ST     bComEnd
```

10.2 Communication with the safety system

```
LD      bComEnd
```

```
JMPC  END
```

```
RESTORE :
```

```
LD      FALSE
```

```
ST      bAcknowledgeToolChangeA0
```

```
ST      bAcknowledgeToolTypeA1
```

```
ST      bAcknowledgeToolTypeA2
```

```
LD      TRUE
```

```
R      bStartCom
```

```
R      bToolValid
```

```
END :
```

```
END_FUNCTION_BLOCK
```



11.1 Technical details

Technical details	
Function	Camera-based protection system
Application area	EN 61496-1,-2, prEN 12622, EN 61508
Detection zone	
Length	0.1 m ... 10 m
Height	Max. 20 mm
Width	44 mm
Reaction time	4 ms
Category	Type 4 in accordance with IEC 61496-1
Resolution of protected field	
Object size	7 mm
Resolution of advance measuring field	
Sheet thickness	2 mm
Required penetration depth	
From side	1.6 mm
From top or bottom	1.6 mm
Transmitter's electrical data	
Number of inputs	2
Supply voltage	24 VDC
Tolerance range	20 V ... 30 VDC including residual ripple of max. ± 1.2 V
Current consumption	0.2 A at 24 VDC
Connection type	M12, 4-pin
Cable cross section	Min. 0.14 mm ²
Light source	High Power LED
Service life	50 000 hours
Diameter of illuminated target area	70 mm
Receiver's electrical data	
Supply voltage	24 VDC
Tolerance range	20 V ... 30 VDC including residual ripple of max. ± 1.2 V
Current consumption	Max. 2 A at 24 VDC
Connection type	2 x M12, 8-pin
Inputs on the receiver	
Number	5
Galvanic isolation	No
Signal level at "0"	-3 V ... +5 VDC
Signal level at "1"	+15 V ... +30 VDC
Input current	Typ. 6 mA
Recognition time	Min. 100 ms
Outputs on the receiver	
Number of positive-switching single-pole semiconductor outputs	8
Galvanic isolation	No
Output current at "1"	Max. 0.25 A at 24 VDC
Permitted range	0 ... 0.32 A
Short circuit protection	Electronic
Min. pulse width at "0" signal (off time)	100 ms
Max. cable length with cable cross section 0.25 mm ²	150 m

11.1 Technical details

Outputs on the receiver	
OSSD/Mute in accordance with EN 61496-1, type 4	
Signal level at "0"	0 VDC (-3 V ... 2 V in accordance with EN 61496)
Signal level at "1"	UB - 1 VDC (11 V ... 30 V in accordance with EN 61496)
Residual current at "0" signal	Max. 1 mA (<2 mA in accordance with EN 61496)
Duration of on and off time during self test	40 µs
Max. cable resistance for detection of shorts between contacts	16 Ohm
Max. capacitive load	20 nF for $R_L > 48$ ohms with rated voltage
Max. inductive load	0.5 H
Transmitter synchronisation	
Max. capacitive load	500 nF
Environmental data	
Protection type (EN 60529)	IP54
Ambient temperature (EN 60068-2-14)	0 °C ... 50 °C
Storage temperature (EN 60068-2-1, EN 60068-2-2)	-35 °C ... 70 °C
Climatic suitability (EN 60068-2-78)	93 % rel. h. at 40 °C
Condensation	Not permitted
Vibration (EN 60068-2-6)	Frequency range: 10 Hz ... 55 Hz Amplitude: 0.35 mm 20 cycles per axis
Shock (EN 60068-2-29)	10 g, 16 ms
EMC	EN 61000-6-4, EN 61496-1
Mechanical data	
Dimensions (H x W x D)	
Transmitter	115.5 mm x 112 mm x 168 mm
Receiver	115.5 mm x 112 mm x 228 mm
Weight	
Transmitter	1700 g
Receiver	2900 g

The standards valid on 2010-03 apply.

Safety characteristic data

Unit	Operating mode	EN ISO 13849-1 PL	EN 954-1 Category	EN IEC 62061 SIL CL	PFH [1/h]	t_M [year]
PSEnvip	---	PL e (Cat. 4)	Cat. 4	SIL CL 3	5.08E-9 (T = 40 °C)	20

All the units used within a safety function must be considered when calculating the safety characteristic data.

11.2 Order reference

Order reference: PSEnvip RL D P Set

Designation	Order no.
PSEnvip RL D P Set Complete PSEnvip set	583 007

Order reference: Accessories

Designation	Order no.
PSEnvip RL D P PSEnvip receiver with display	583 601
PSEnvip T PSEnvip transmitter	583 900
PSEnvip TP Test piece	583 200
PSEnvip AP Set of adjustment plates for transmitter/receiver	583 202
PSEnvip AT mag Adjustment templates with magnets	583 203
PSEnvip AT mech Adjustment templates for bracket mounting	583 204
PSEnvip MB Set of adapter plates for transmitter and receiver	583 205
PSEnvip MS Right and left bracket for transmitter and receiver	583 206
PSEN op cable axial M12 4-p. screening 5 m Straight plug, 4-pin, screened, 5 m for transmitter	630 304
PSEN op cable axial M12 4-p. screening 10 m Straight plug, 4-pin, screened, 10 m for transmitter	630 305
PSEN op cable axial M12 4-p. screening 30 m Straight plug, 4-pin, screened, 30 m for transmitter	630 309
PSEN op cable axial M12 8-p. screening 5 m Straight plug, 8-pin, screened, 5 m for receiver	630 314
PSEN op cable axial M12 8-p. screening 10 m Straight plug, 8-pin, screened, 10 m for receiver	630 315
PSEN op cable axial M12 8-p. screening 30 m Straight plug, 8-pin, screened, 30 m for receiver	630 328

The names of products, goods and technologies used in this manual are trademarks of the respective companies.



12.1 Check list

The following check list is intended as a guide to provide support when commissioning and recommissioning the PSEnvip and when carrying out the regular inspection as required.

Please note that the check list is not intended to replace the plant-specific safety analysis required for commissioning/recommissioning, nor the resulting inspections and actions.



INFORMATION

Commissioning, recommissioning and the regular inspection may only be carried out by qualified personnel.

We recommend that you keep the completed check list and store it with the machine documentation for reference.

No.	Action	OK	Not OK	Remarks
1	Check the category/standards			
	Does the category of the PSEnvip match the category required for the plant/machine?			
	Have the standards applicable for the plant/machine been considered?			
2	Check the ambient conditions for PSEnvip			
	Are the technical details of the PSEnvip complied with?			
3	Check the wiring of the PSEnvip			
	Are all the electrical connections to the PSEnvip wired correctly?			
	Do the power supply for generating the 24 V supply voltage and the voltages to the inputs on the PSEnvip comply with the regulations for safe electrical isolation?			
	Are the cables adequately shielded?			

12.1 Check list

No.	Action	OK	Not OK	Remarks
4	Visual inspection			
	Make sure that there are no objects in the protected space between the transmitter and receiver.			
	Make sure that there are no transparent materials between the transmitter and receiver (e.g. glass panel).			
	Are all the mechanical connections to the PSEnvip attached correctly?			
	Cables are undamaged?			
5	Check commissioning			
	Has the system been commissioned correctly in accordance with the documentation?			
6	Check the circuitry of the programmable safety and control system			
	Have the outputs that have been defined as OSSDs been incorporated in accordance with the required category?			
	Are the switching elements that are connected to the outputs (e.g. valves, contactors) monitored via feedback loops?			
	Does the wiring of the inputs and outputs match the circuit diagram?			
7	Check the effectiveness of the PSEnvip during the hazardous movement			
	Is the PSEnvip effective throughout the whole of the hazardous movement of the plant/machine?			
	Is the safety function tested in accordance with the instructions specified in this documentation?			
8	Check protected field modes			
	Do the protected field modes operate in accordance with the setting of the operating mode selector switch?			

Date:

Signature:

12.2 EC declaration of conformity

more than automation
safe automation

EG-Konformitätserklärung

EC-Declaration of Conformity

Originalerklärung/original declaration

Wir **Pilz GmbH & Co. KG, Felix-Wankel-Str. 2, 73760 Ostfildern, Deutschland**
 We **Pilz GmbH & Co. KG, Felix-Wankel-Str. 2, 73760 Ostfildern, Germany**

erklären in alleiniger Verantwortung, dass das Produkt
 declare under our sole responsibility that the product

PSEnvip RL D Set (PSEnvip T, PSEnvip RL D), PSEnvip RL D P Set (PSEnvip T, PSEnvip RL D P), PSEnvip RL D M Set (PSEnvip T, PSEnvip RL D M)
Mitfahrende Schutzeinrichtung zur Absicherung der Gefahrenstelle unter dem Werkzeug von Abkantpressen
Mobile protection system for safeguarding the danger point below the press brake tool

Sicherheitsbauteil nach EG-Richtlinie 2006/42/EG, Anhang IV
Safety component according to EC guideline 2006/42 EC, annex IV

auf das sich diese Erklärung bezieht, mit der/den folgenden Norm(en) oder normativen
 Dokument(en) übereinstimmt.
to which this declaration relates is in conformity with the following standard(s) or other normative document(s).

EN 61496-1: 2004; CLC/TS 61496-2:2006; EN 61508:2001; EN ISO 13849-1:2008 ; EN 61000-6-2: 2005; EN 55011: 2007

Das bezeichnete Produkt entspricht den folgenden europäischen Richtlinien:
The described product corresponds to the following European Directives:

2004/108/EG EMV-Richtlinie /EC EMC directive
 2006/42/EG Maschinenrichtlinie /EC Machinery directive

Die Übereinstimmung eines Baumusters des bezeichneten Produkts mit der Richtlinien Nr.:
Consistency of a production sample with the marked product in accordance with the Directives No.:

2006/42/EG Maschinenrichtlinie /EC Machinery directive

wurde bescheinigt durch:
has been certified by:
 Notifizierte Stelle/Anschrift: **TÜV NORD CERT GmbH**
Notified agency/Address: **Langemarckstrasse 20**
45141 ESSEN
Kennnummer 0044

Nummer der Bescheinigung: 44 205 10 555183 000
Certification number:

Das bezeichnete Produkt stimmt mit dem geprüften Baumuster überein.
The marked product is consistent with the examined production sample.

Herr Fröhlich ist bevollmächtigt, die technischen Unterlagen zusammenzustellen
Mr. Fröhlich is authorized to prepare the technical documentation

Ostfildern
 07.05.2010 Norbert Fröhlich
Letter Entwicklung Produkte/Manager Product Development

Ort und Datum der Ausstellung/Place and date of issue Name und Unterschrift/Name and signature

Filename: Ce_Declaration_PSEnvip_Pilz

 EP Version 4.0, 2007-07
 Diese Konformitätserklärung entspricht der Europäischen Norm EN ISO/IEC 17050-1:2004-10 „Konformitätsbewertung - Konformitätserklärung von Anbietern Teil 1: Allgemeine Anforderungen“
 This declaration of conformity is suitable to the European Standard EN ISO/IEC 17050-1:2004-10 „Conformity assessment - Supplier's declaration of conformity - Part 1: General requirements“

